

SHOP MANUAL

HONDA
50

MODEL
Z50A

HONDA MOTOR CO., LTD.

⊗ '69 3. ⊗-B 2,500
PRINTED IN JAPAN

FOREWORD

This Shop Manual is a servicing guide for the Z50A.

Many photographs and illustrations were used to provide the serviceman with clear and easy understanding. To ensure proper servicing, the special tools must be used and all repairs made to the specified tolerances.

HONDA MOTOR CO., LTD.
Service Division

CONTENTS

MAIN FEATURES OF Z50A	1
SPECIFICATION TABLE	3
SPECIAL TOOL SET	4
ENGINE	6
1. Engine Assembly Diagram	6
2. Engine Removal	7
3. Engine Installation	7
4. Lubrication (Oil Pump)	8
5. Cylinder and Cylinder Head	9
6. Piston and Piston Ring	15
7. Clutch	17
8. Crankshaft	18
9. Transmission	20
10. Gear Shift Mechanism	21
11. Kick Starter	23
12. Carburetor	24
TRUBLE SHOOTING TABLE	27
FRAME	
1. Front Suspension	31
WIRING DIAGRAM	32

MAIN FEATURES OF Z50A

- The overhead cam design enables a quiet operation and a constant high output over a broad speed range starting at slow speed with very little effort.
- Incorporation of the oil damper type cam chain tensioner automatically maintains the proper tension and minimizes the chain noise, further, chain adjustment is unnecessary.
- Riding is simplified by the use of the automatic clutch which is interconnected with the gear change pedal.
- Metal screen and centrifugal filter assures only clean oil to lubricate the critical moving parts.
- Foldable handle bar makes storing in narrow space possible.
- Frame is welded pipe backbone design having a double channel welded to a single main pipe to reduce weight.
- To prevent spillage of fuel during transportation fuel shut off valves are provided in the filler cap and the carburetor.

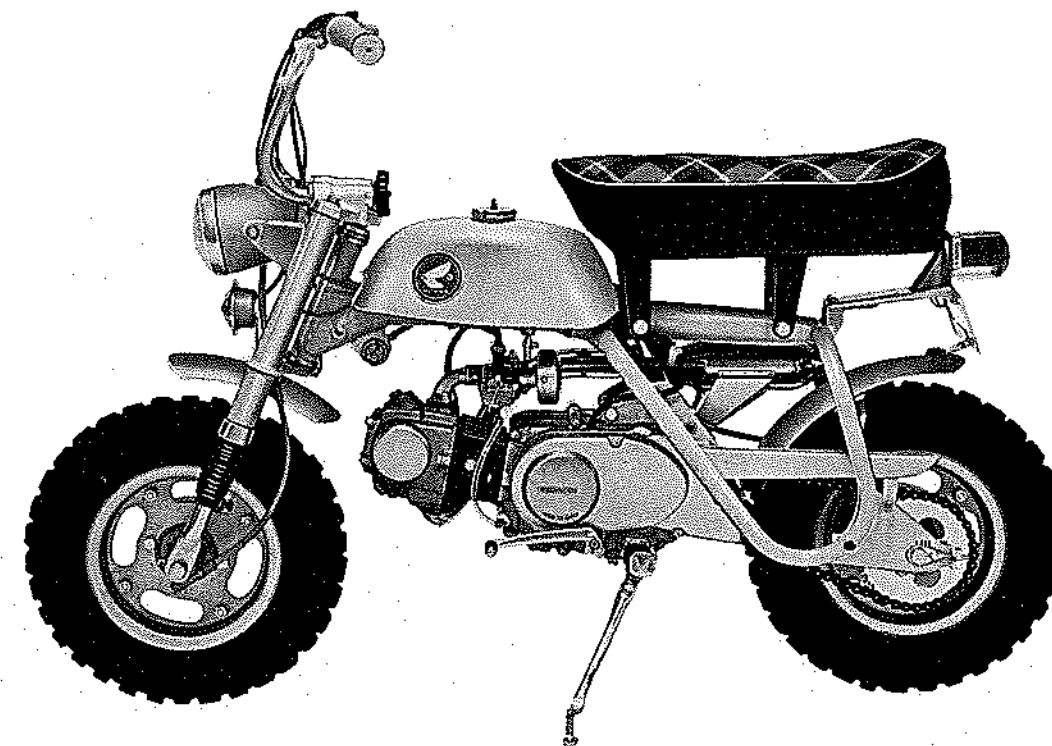

GENERAL EXPORT TYPE

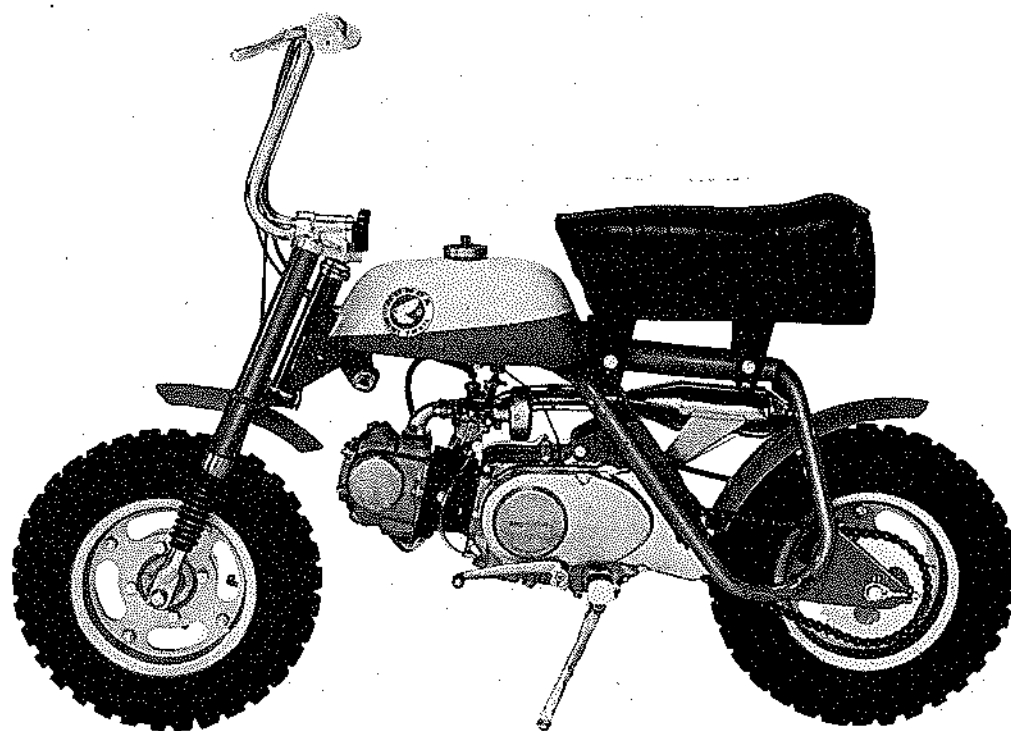

U.S.A. TYPE (From F. No. 100001)

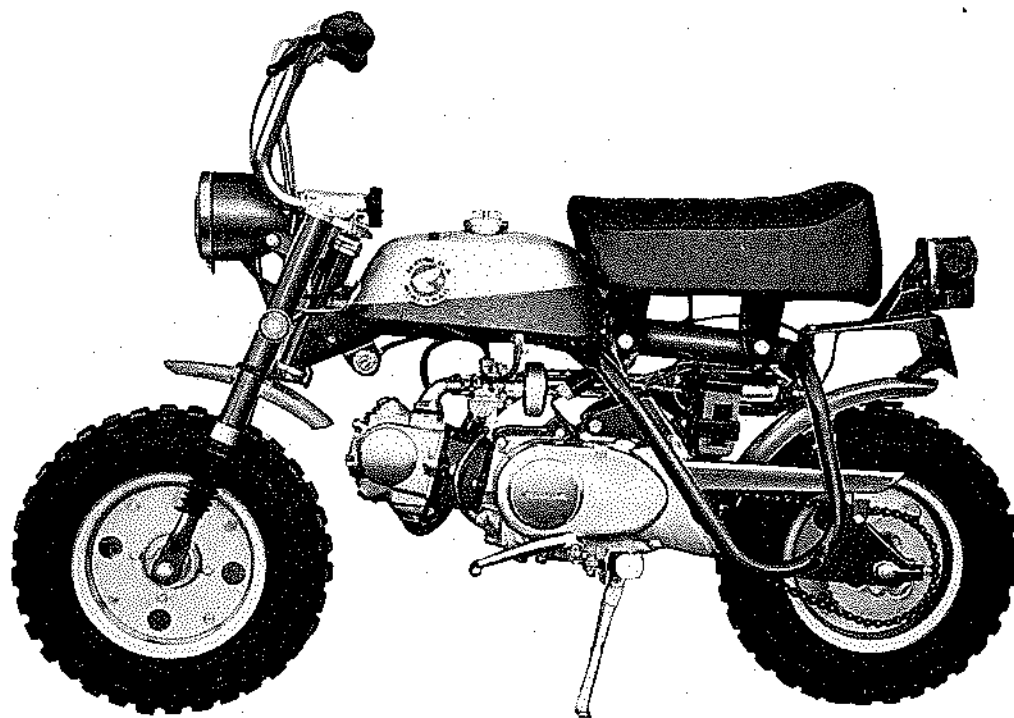

U.S.A. TYPE (From F. No. 120001)

SPECIFICATION TABLE

	U.S.A. TYPE (From F. No. 100001) GENERAL EXPORT TYPE	U.S.A. TYPE (From No. F. 120001)
DIMENSION		
Overall length	1,270 mm (50.0 in)	Same as left
Overall width	635 mm (25.0 in)	590 mm (23.2 in)
Overall height	1,000 mm (39.4 in)	860 mm (33.9 in)
Wheel base	880 mm (34.7 in)	Same as left
Min. ground clearance	170 mm (6.7 in)	Same as left
Curb weight	49 kg (108 lbs)	50 kg (110lbs)
FRAME		
Suspension (F)	Telescopic fork	
Suspension (R)	Rigid frame	
Brakes	Internal expansion	
Fuel tank capacity	2.5 lit. (0.7 U.S. gal., 0.6 Imp. gal.)	
Trail	40 mm (1.57 in)	
Caster	67°	
Tire size and air pressure (F & R)	3.50-8, 1.0 kg/cm ² (14.2 psi)	
ENGINE		
Cylinder layout	Single, tilt up 10° from horizontal	
Valve arrangement	OHV w/overhead camshaft	
Bore and stroke	39×41.4 mm (1.535×1.630 in)	
Compression ratio	8.8	
Displacement	49 cc (3.0 cu-in)	
Oil capacity	0.8 lit. (1.7 U.S. pt., 1.4 Imp. pt.)	
Lubrication	Pressure lubrication & wet sump	
Oil filters	Centrifugal and screen mesh	
Reduction ratios		
Primary	3.722	
Secondary	2.615	
Gear ratios		
1st	3.182	
2nd	1.824	
3rd	1.190	
Starting method	Kick starter	
PERFORMANCE		
Max. speed	45 kph (28 mph)	
Max. torque	0.31 kg-m/4,200 rpm (2.2 ft-lb/4,200 rpm)	
Max. output	1.95 ps/5,000 rpm	
Fuel consumption	70 km/lit. at 20 kph (165 mile/U.S. gal., 198 mile/Imp. gal. at 12 mph)	
Climbing ability	17°	
Min. turning circle	2.6 m (8.6 ft)	
Braking distance	3.5 m at 20 kph (11.5 ft. at 12 mph)	
ELECTRICAL		
Ignition	Flywheel magneto	
Spark plug	NGK C-6 H or ND U20FS	
Head light	6V-15W (General export type)	6V-15/15W
Tail/stop light	6V-8/3W (General export type)	6V-17/5.3W

SPECIAL TOOL SET

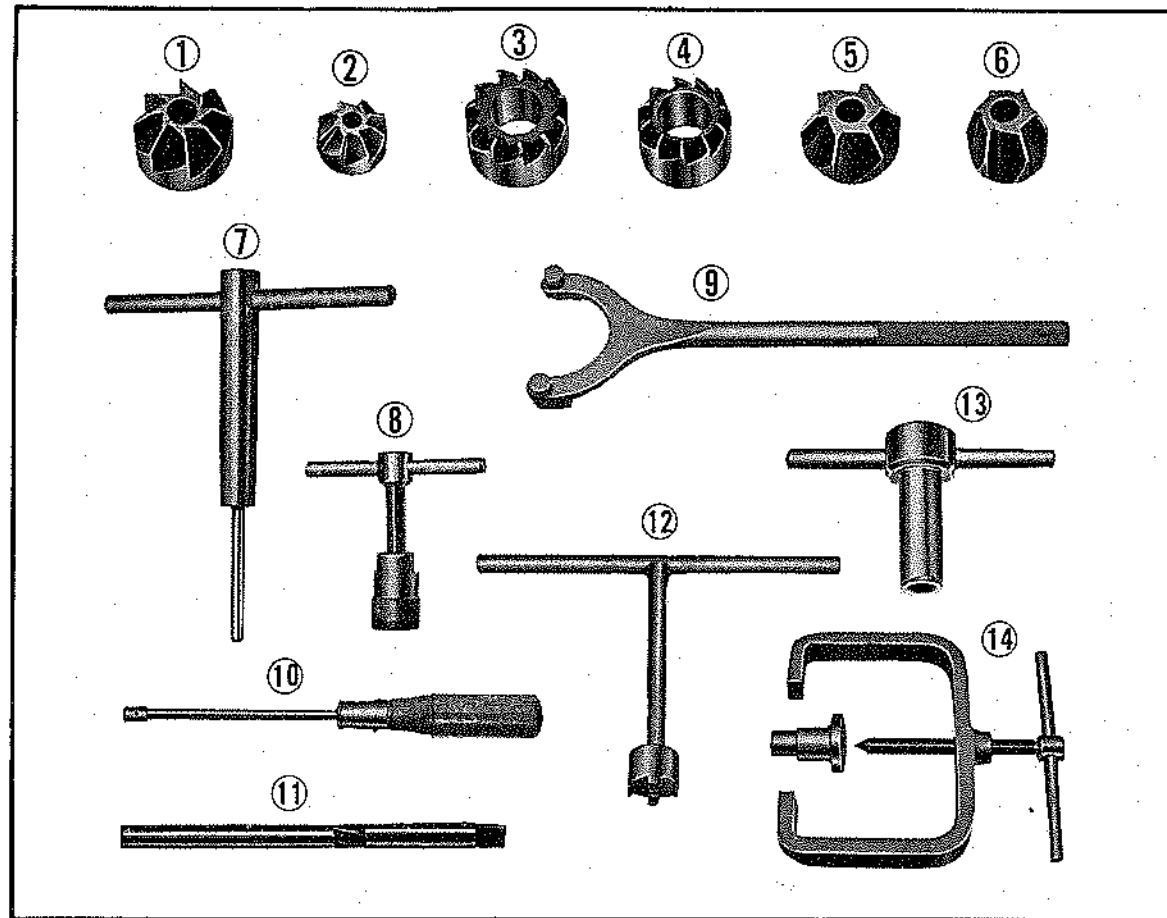

Ref. No.	Tool No.	Description
	07000-04511	Z50M/Z50A Special tool set
1	07001-03602	Inlet valve seat cutter, 90°
2	07002-03602	Exhaust valve seat cutter, 90°
3	07003-03601	Inlet valve seat top cutter
4	07004-03601	Exhaust valve seat top cutter
5	07005-03601	Inlet valve seat interior cutter
6	07006-03601	Exhaust valve seat interior cutter
7	07007-03601	Valve seat cutter holder
8	07016-00102	Flywheel puller
9	07025-00102	Flywheel holder
10	07081-00101	Tappet adjusting socket wrench
11	07008-24001	Valve guide reamer
12	07086-00102	Lock nut wrench, 14 mm
13	07087-00101	Tappet lock nut socket wrench
14	07038-01101	Clutch disassembling & assembling tool

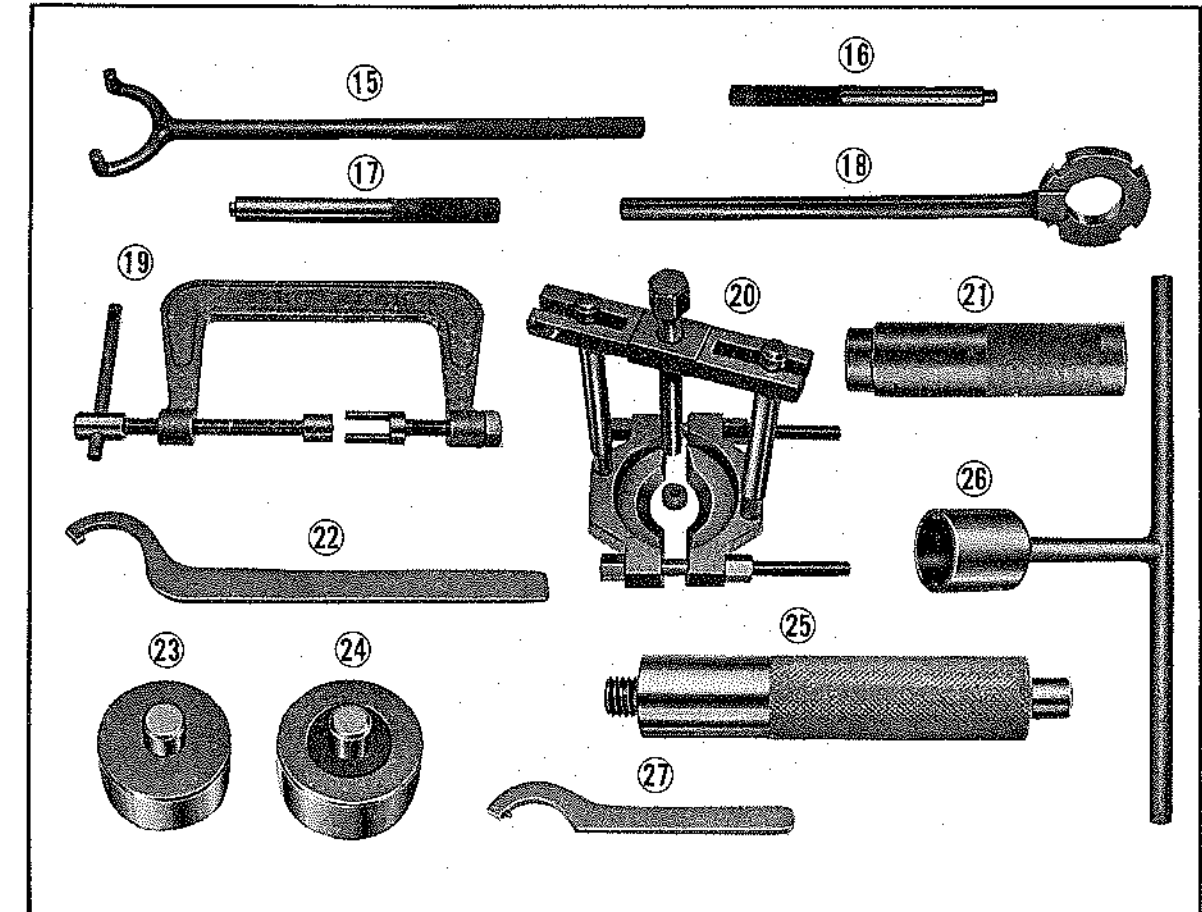

Ref. No.	Tool No.	Description
15	07022-04001	Drive sprocket holder
16	07047-04001	Valve guide remover
17	07046-21601	Valve guide driver
18	07024-03501	Clutch outer holder
19	07031-20001	Valve lifter
20	07784-99908	Universal bearing puller
21	07048-81501	Bearing driver
22	07072-00101	Pin spanner, 36 mm
23	07048-04501	Front wheel oil seal driver
24	07054-04501	Rear wheel bearing driver
25	07048-04505	Bearing & oil seal driver handle
26	07083-03001	Stem nut socket wrench
27	07071-25001	Main switch pin spanner
28	07997-05101	Valve seat cutter case
29	07790-29201	Tool case (A)

ENGINE

1. ENGINE ASSEMBLY DIAGRAM

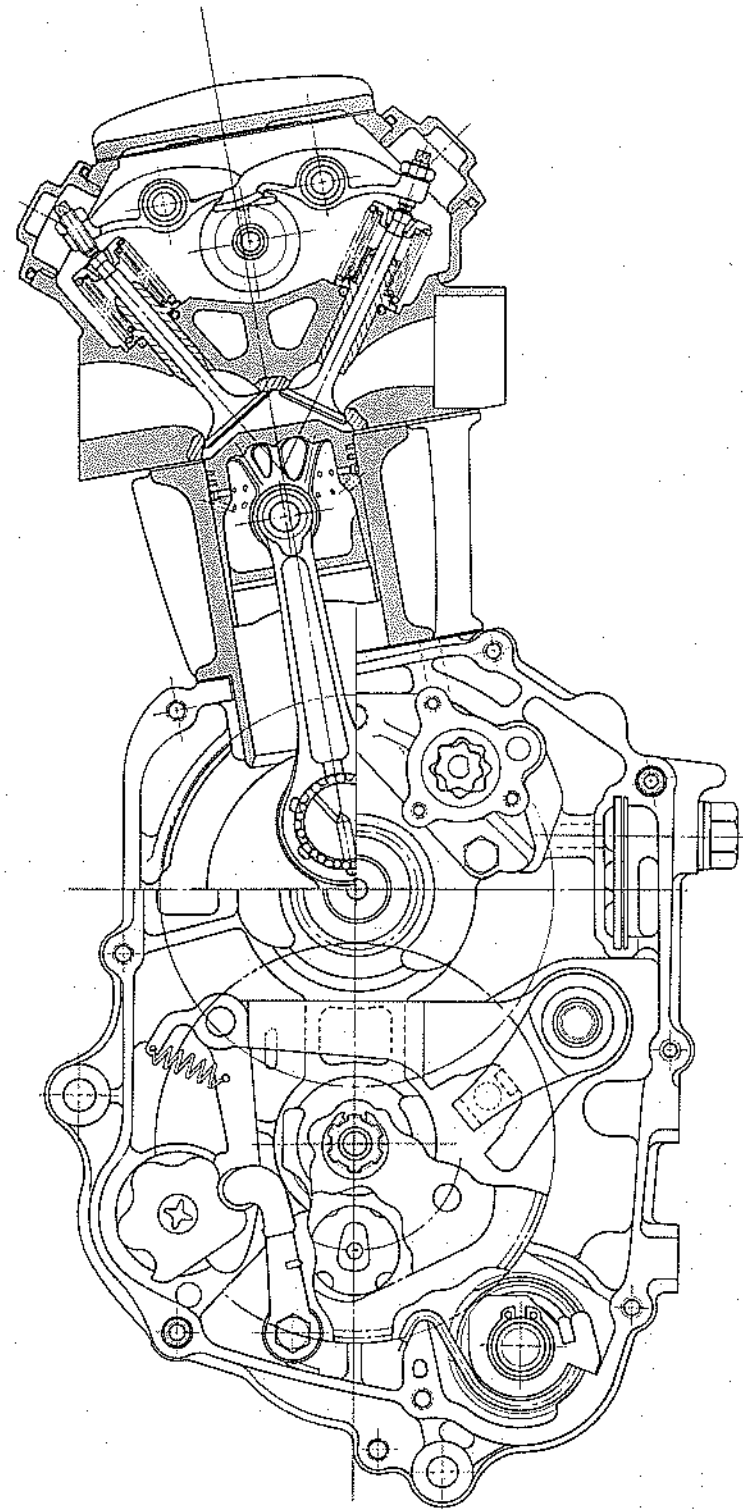
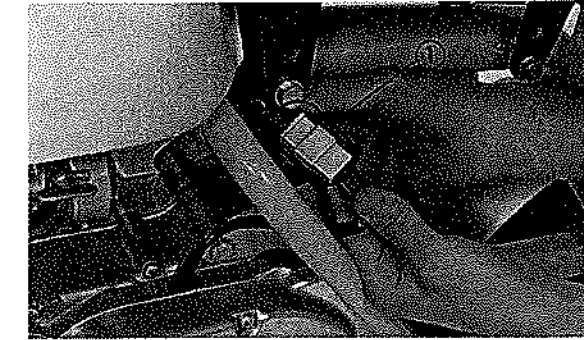

Fig. 1

2. ENGINE REMOVAL

1. Loosen the muffler flange and mounting bolts, and remove the muffler.
2. Disconnect the throttle cable from the carburetor.
3. Detach the high tension cord by pulling the plug cap off the spark plug.
4. Disconnect the electrical wiring (Fig. 2).



① Electric leads coupler
Fig. 2

5. Set the fuel cock to the OFF position and disconnect the fuel tube from the carburetor.
6. Unscrew the left crankcase cover mounting screws and remove the cover.
7. Unfasten the drive chain joint clip and disconnect the chain.
8. Remove the two engine hanger bolts and dismount the engine from the frame (Fig. 3).

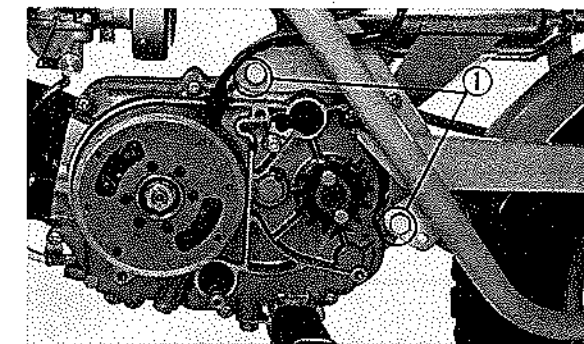

① Engine hanger bolts
Fig. 3

3. ENGINE INSTALLATION

Perform the engine installation in the reverse order of the engine removal described above.

Note: When installing the drive chain joint clip, make sure that the open end of the clip is in the opposite direction to the normal chain rotation (Fig. 4.)

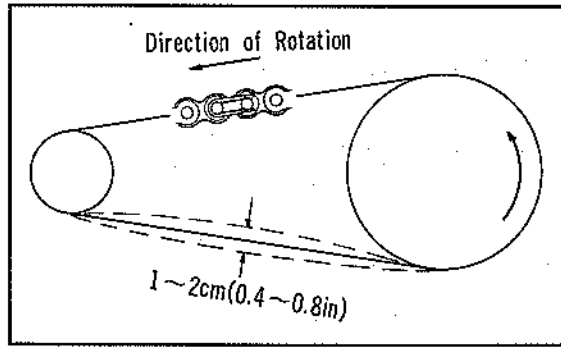

Fig. 4 Chain joint clip installation

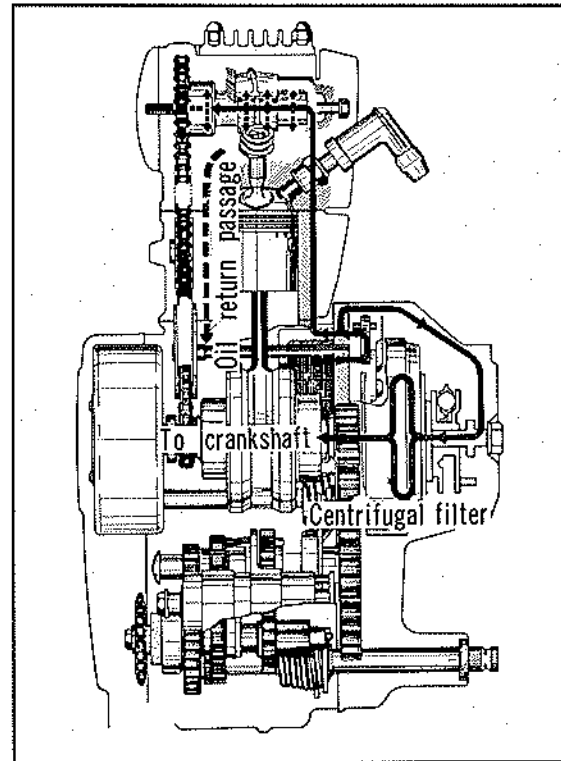
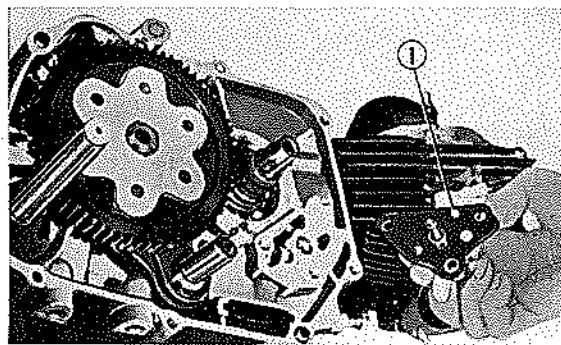

Fig. 5 Engine oil routes



① Oil pump assembly
Fig. 6

4. LUBRICATION (OIL PUMP)

A. Description

The engine oil which has been picked up by the trochoid pump is diverted into two routes (Fig. 5).

Route one:

Oil is sent through the right crankcase → right crankcase cover → centrifugal filter → connecting rod large end rollers

Route two:

Oil is sent through the cylinder stud bolt → rocker arm side cover → camshaft profiles and bearings → valve mechanism.

B. Disassembly

1. Unscrew the right crankcase cover mounting screws and remove the cover.
2. Remove the clutch outer cover.
3. Unscrew and remove the 14 mm clutch lock nut and washer, and then remove the clutch assembly.
4. Loosen the three 6 mm oil pump mounting bolts and remove the oil pump assembly.
5. Loosen the three cross screws attaching the oil pump cover, the oil pump can then be disassembled (Fig. 6).

C. Inspection

1. Turn the oil pump drive shaft by hand and make sure that it is turning smoothly.
2. Measuring the clearance between the outer rotor and the pump body. Insert the thickness gauge between the outer rotor and the pump body (Fig. 7).

Standard Value	Serviceable Limit
0.004~0.006 (0.10~0.15 mm)	Replace if over 0.0079 (0.20 mm)

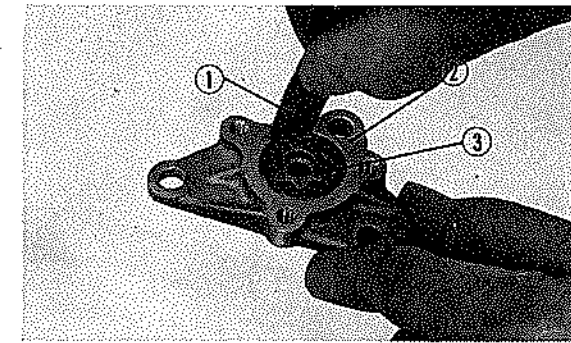

① Thickness gauge ② Pump body ③ Outer rotor
Fig. 7

3. Measuring the end clearance of the rotor. Place a straight edge across the pump housing and check the clearance of the rotor with a thickness gauge (Fig. 8).

Standard Value	Serviceable Limit
0.0008~0.0027 (0.02~0.07 mm)	Replace if over 0.0047 (0.12 mm)

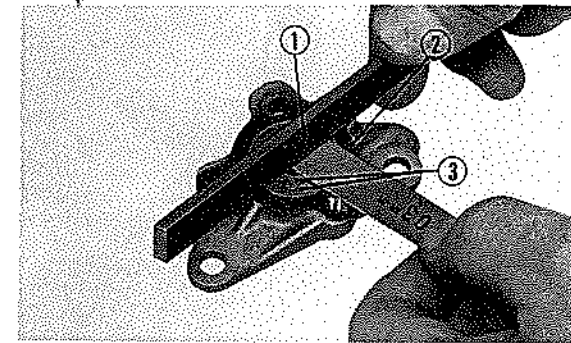

① Straight edge ② Pump body ③ Rotor
Fig. 8

D. Reassembly

Perform the reassembly in the reverse order of disassembly procedure, however, particular attention should be paid to the following items (Fig. 9).

1. Make sure that the parts are thoroughly cleaned before assembly.
2. After completing the reassembly of the pump, check to make sure that the pump is operating smoothly by turning the shaft by hand before mounting the pump in the crankcase.

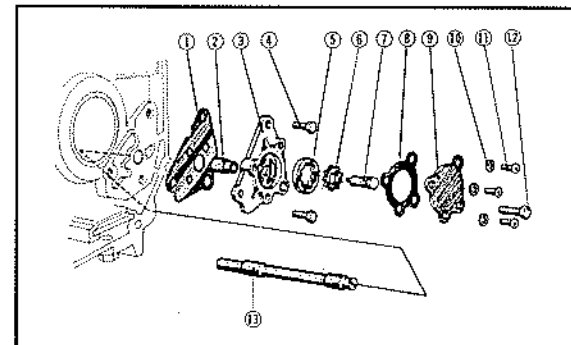

① Oil pump body gasket ② Oil pump dwell pin
③ Oil pump body ④ 6 mm hex. bolt
⑤ Oil pump outer rotor ⑥ Oil pump inner rotor
⑦ Oil pump drive shaft ⑧ Oil pump cover gasket
⑨ Oil pump cover ⑩ 5 mm spring washer
⑪ 5 mm cross screw ⑫ 6 mm hex. bolt
⑬ Cam chain guide sprocket spindle
Fig. 9

5. CYLINDER AND CYLINDER HEAD

A. Description

The cylinder head is made of aluminum alloy to improve the cooling effect. Cylinder is made of special cast iron which provides good wear characteristics without being affected by high temperature and pressure.

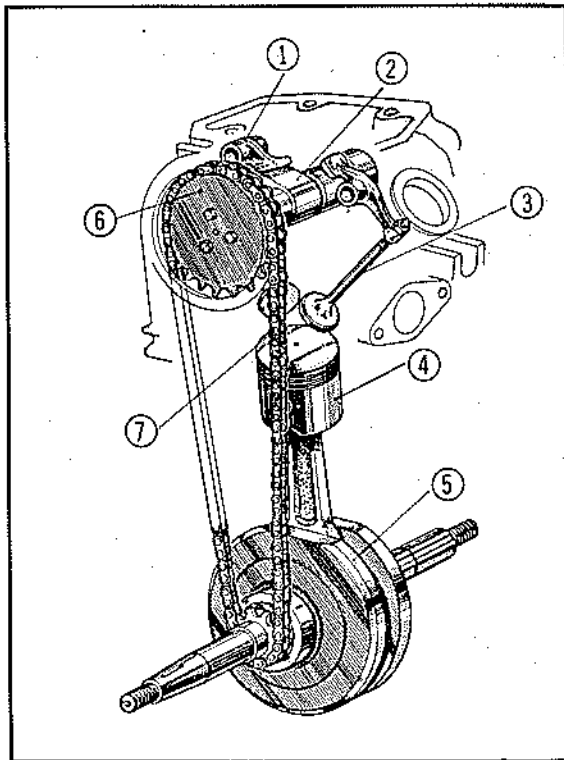

① Rocker arm ② Camshaft ③ Valve ④ Piston
⑤ Crankshaft ⑥ Cam sprocket ⑦ Camchain
Fig. 10

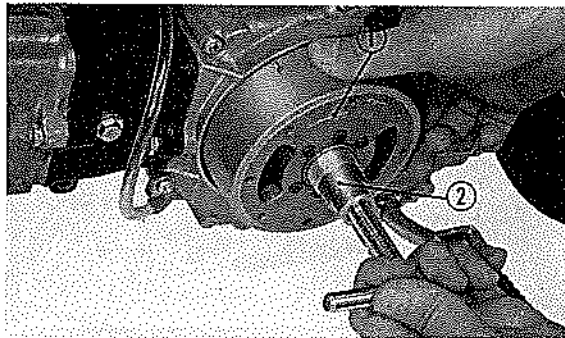

① Flywheel generator ② Flywheel puller
Fig. 11

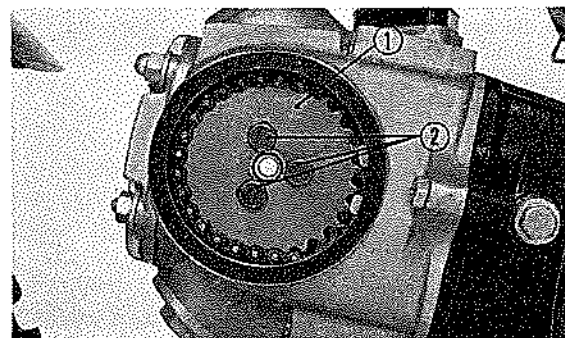

① Cam sprocket ② Sprocket setting bolts
Fig. 12

B. Disassembly

1. Drain the engine oil by removing the drain plug.
2. Unscrew the left crankcase cover mounting screws and remove the cover.

3. Remove the flywheel using the flywheel puller (Tool No. 07016-00102) and then remove the stator assembly (Fig. 11).

4. Loosen the 6 mm hex bolt from the left cylinder head side cover and remove the side cover. Also loosen the two cross screws and remove the right cylinder head side cover.

5. Loosen the three cam sprocket mounting bolts and remove the cam sprocket from the camshaft (Fig. 12).

6. Unscrew the four cylinder head hold-down nuts and 6mm hex. bolt and then separate the cylinder head from the cylinder.

7. Loosen the cam chain guide roller pin and remove the cam chain guide roller from the cylinder (Fig. 13).
8. Unscrew the cylinder mounting bolt (1 each) and remove the cylinder.
9. Disassemble the valve rocker arm and the camshaft from the cylinder head.

10. Disassemble the valve by using the valve removal tool (Tool No. 07031-20001) (Fig. 14).

C. Inspection

1. Inspecting the cylinder head machined gasketing surface.

Place a straight edge across the machined gasketing surface and measure the clearance between the straight edge and the machined surface with a thickness gauge. If the clearance is greater than 0.002 (0.05 mm), the cylinder head should be repaired or replaced.

To perform the repair, place a sheet of fine grit emery paper on the lapping or surface plate and rework the cylinder head. The condition of the machined surface can be checked by using prussian blue or red lead (Fig. 16).

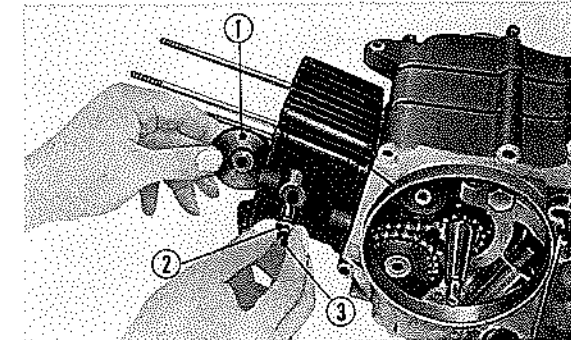

① Cam chain guide roller ② 8 mm sealing washer
③ Cam chain guide roller pin
Fig. 13

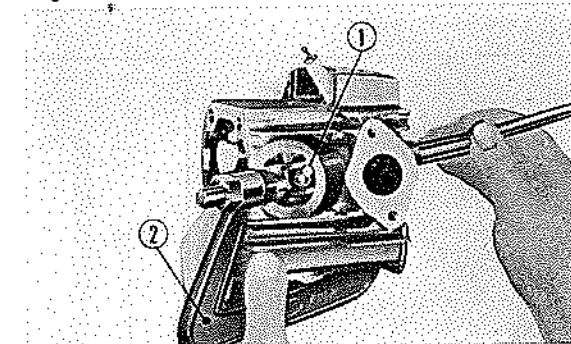

① Valve cotter ② Valve lifter
Fig. 14

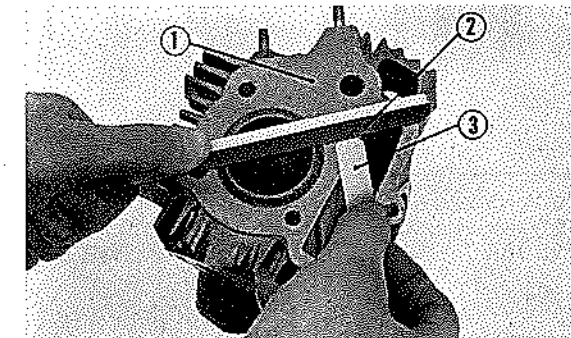

① Cylinder head ② Straight edge
③ Thickness gauge
Fig. 15

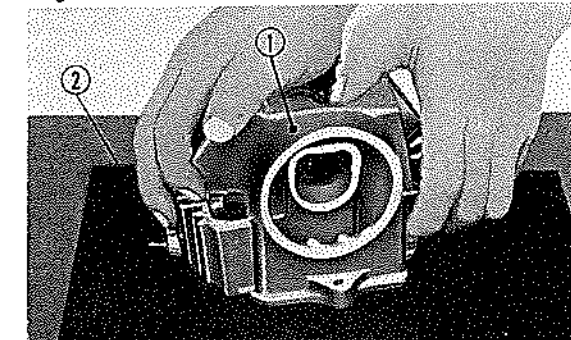

① Cylinder head ② Emery paper
Fig. 16

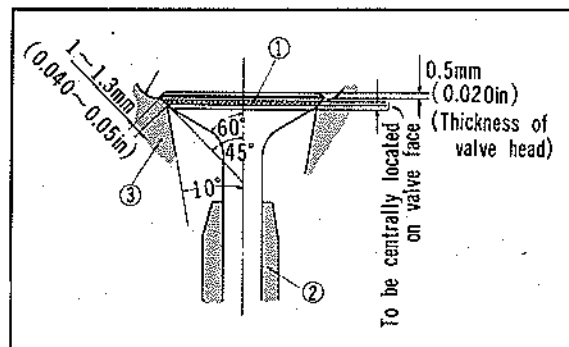

① Valve face contact area ② Valve guide
③ Cylinder head body
Fig. 17

2. Inspecting the valve seat

The standard width of the valve contact surface is 0.040-0.051 (1.0-1.3 mm). When the contact surface becomes wider than 0.080 (2.0mm), the valve seat should be repaired with a seat cutter (included in the special tools). Valve seat is cut to the proper dimension using the valve seat top and interior cutters. The 90° seat cutter is used to repair the valve seat contact surface.

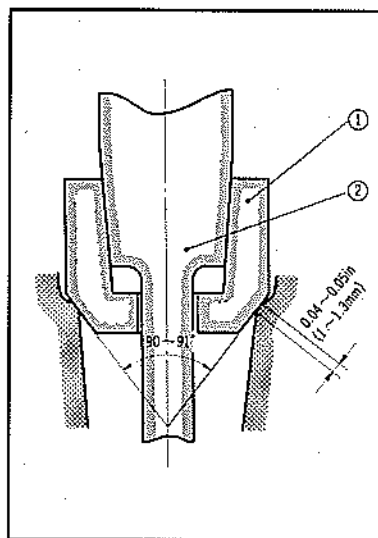

① Valve seat cutter 90°
② Valve seat cutter holder
Fig. 18A

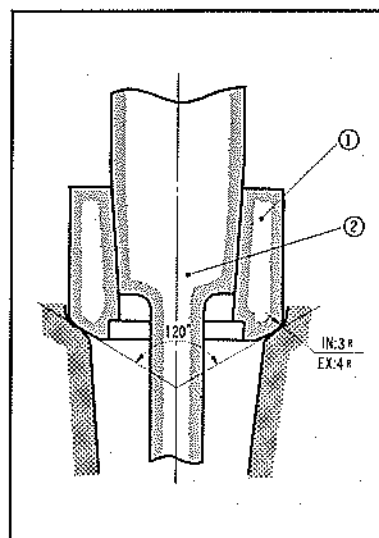

① Valve seat top cutter
② Valve seat cutter holder
Fig. 18B

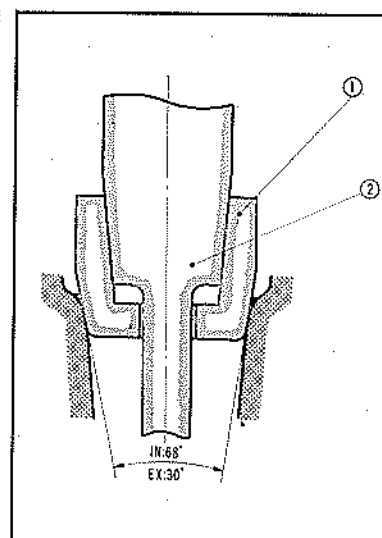

① Valve seat interior cutter
② Valve seat cutter holder
Fig. 18C

Whenever the valve seat has been repaired or the valve replaced, the valve must be lapped to the seat.

To lap the valve, apply a small amount of lapping compound to the valve contact surface and rotate the valve back and forth against the seat using a suction cup tool; lifting the valve off the seat occasionally. After the valve lapping is completed, wash off the lapping compound thoroughly from both the seat and face of the valve. Finally, check the seating of the valve with Prussian blue or red lead to assure that a good seat has been obtained.

Note:

1. Apply a small amount of oil to the valve stem when inserting the valve into the guide.
2. After the valve has been assembled into the cylinder head, check the sealing of the valve by pouring a small quantity of engine oil into the combustion chamber until the valve heads are covered and then apply compressed air at 28.4 psi (2 kg/cm²) alternately into the inlet and exhaust ports and check for any bubbles arising from around the valve seats. If there are no bubbles, the valves are sealing properly.

3. Measuring the wear of the valve stem and valve guide.

Place a dial gauge against the valve stem and move the valve sideways, and fore and aft. The amount of wear in any direction will be indicated on the gauge (Fig. 19).

Item	Standard Value	Serviceable Limit
Inlet	0.0004~0.0012 (0.01~0.03 mm)	Replace if over 0.0032 (0.08 mm)
Exhaust	0.0012~0.002 (0.03~0.05 mm)	Replace if over 0.004 (0.10 mm)

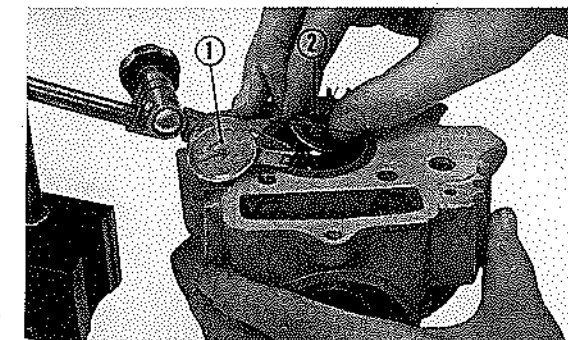

① Small dial gauge ② Valve
Fig. 19

4. Measuring the valve dimension

The valve stem diameter is measured with a micrometer. (Fig. 20)

Item	Standard Value	Serviceable Limit
Inlet	0.2148~0.2187 (5.455~5.465 mm)	Replace if under 0.2126 (5.40 mm)
Exhaust	0.2070~0.2109 (5.435~5.445 mm)	Replace if under 0.2048 (5.38 mm)

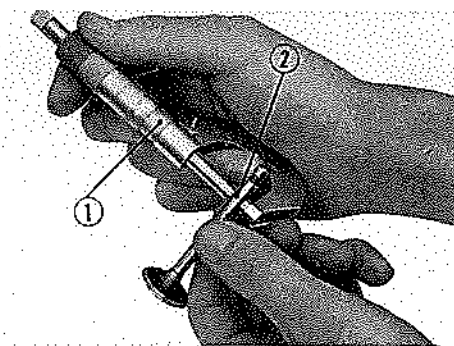

① Micrometer ② Valve
Fig. 20

5. Replacing the valve guide

If the valve guide is worn excessively and requires replacement, follows the procedure below.

- a. Remove the valve guide from the cylinder head using the valve guide remover (Tool No. 07047-04001).
- b. Install the new valve guide using the valve guide driver (Tool No. 07046-21601), and carefully drive the guide into the head. The replacement valve guide should be one that is of an oversize.
- c. After the new valve guide has been installed, it must be reamed to the proper finish size using a guide reamer (Tool No. 07008-24001). Exercise care when using the reamer and apply small amount of oil occasionally to lubricate when the reamer starts to operated hard, pull out the reamer and remove the metal chip before continuing to ream. The standard valve guide diameter is 0.2156-0.2159 (5.475-5.485 mm). Measurement can be made with a cylinder gauge (Fig. 22).

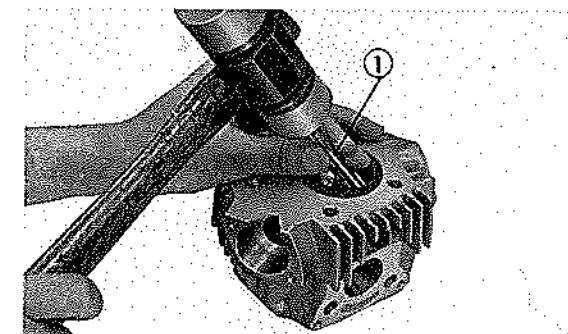

① Valve guide remover
Fig. 21

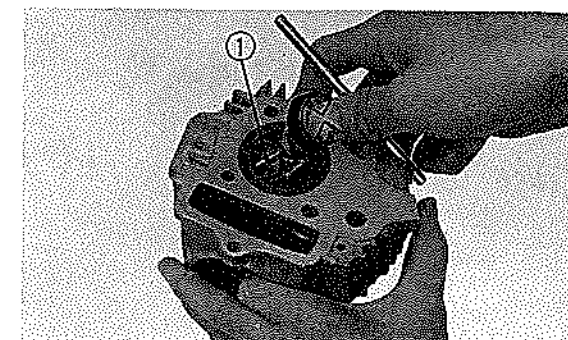

① Valve guide reamer
Fig. 22

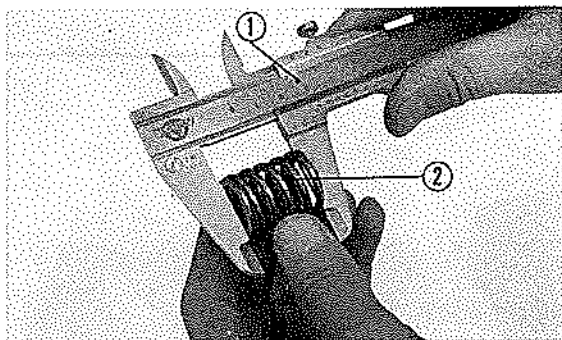

① Vernier caliper ② Valve spring
Fig. 23

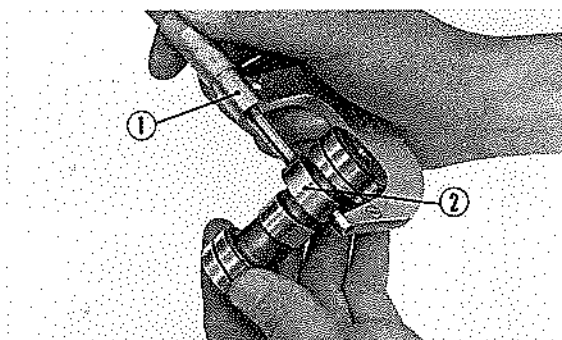

① Micrometer ② Camshaft
Fig. 24

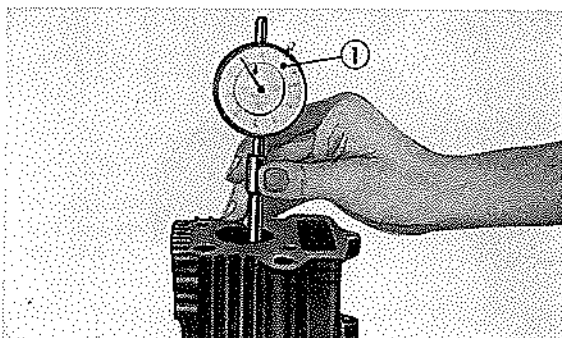

① Cylinder gauge
Fig. 25

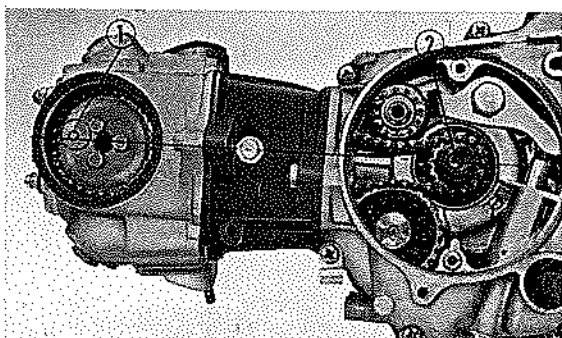

① "O" mark ② Key
Fig. 26

6. Inspecting the valve spring

Measure the length of the valve spring free length with a vernier caliper.

Standard Value	Serviceable Limit
1.11 (28.1 mm)	Replace if under 1.06 (26.9 mm)

7. Inspecting the camshaft

Measure the cam lift with a micrometer

Item	Standard Value	Serviceable Limit
Base circle	0.825 (21.0 mm)	Replace if under 0.819 (20.8 mm)
Cam lift (including the base circle)	1.025 (26.076 mm)	Replace if under 1.015 (25.8 mm)

8. Measuring the inside diameter of the cylinder

Use a cylinder gauge and measure the inside diameter of the cylinder at the top, center and bottom in both the x and Y axes. If the cylinder is excessively worn, it should be either rebored or replaced with a new cylinder depending upon the extent of wear (Fig. 25).

Standard Value	Serviceable Limit
1.5358~1.5362 (39.01~39.02 mm)	39.1 (1.540 mm)

Note :

When reboring the cylinder, it must be rebored to an oversize units of 0.010 (0.25 mm) up to a maximum of 0.40 (1.0 mm) since the piston and the piston ring sets comes in those oversizes only.

D. Reassembly

Perform the reassembly in the reverse order of disassembly which was described in page 9 section B, however, follow the procedure below for timing the valves.

Position the key of the left crankshaft so that it is pointing toward the cylinder head, and position the cam that the "O" marking on the cam sprocket is at the topmost position (Fig. 26).

Note :

1. When installing the cylinder head, the cam sprocket must be contained within the cylinder head (Fig. 27).
2. Make sure that the respective gaskets, dowel pins and rings have not been overlooked.

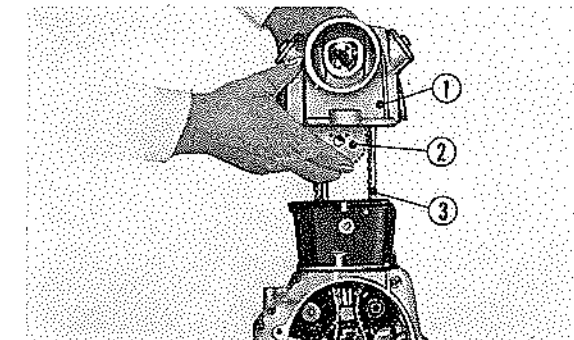

① Cylinder head ② Cam sprocket ③ Cam chain
Fig. 27

3. When torquing down the cylinder head, tighten the nuts uniformly in a diagonal sequence as shown in the Fig. 28 and torque to the final specified torque value of 6.5-9 ft-lb (90-120 kg-cm).

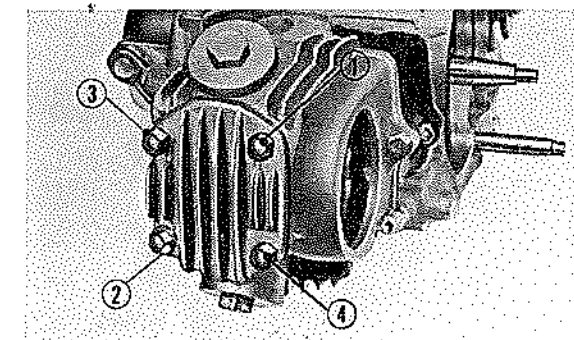

Fig. 28 Torquing sequence

6. PISTON AND PISTON RINGS

A. Description

The piston is made of special SAE 332 aluminum alloy to minimize material deformation caused by high temperature and also because of its good wear resistant qualities. The piston rings especially should be highly resistant and therefore, they are hard chrome plated or wet honed to give it the desired characteristics.

B. Disassembly

1. The piston is disassembled from the connecting rod by first removing the piston pin clip and then the piston pin (Fig. 29).

Note :

1. When removing the piston pin clip, place a rag under the piston so that the clip will not fall into the crankcase if it should accidentally be dropped.
2. To remove the piston rings from the piston, it is recommended that the piston ring remover be used, however, if one is not available, they can be removed by hand, but care should be exercised so that they are not broken.

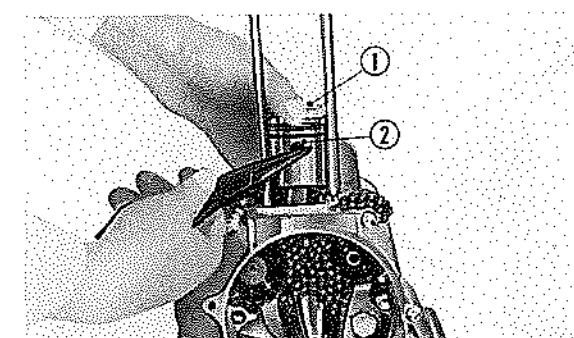

① Piston ② Piston pin clip
Fig. 29

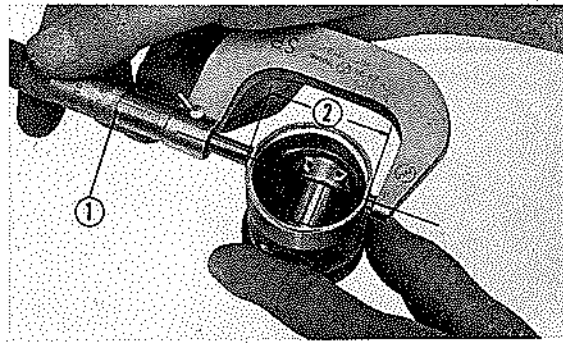

① Micrometer ② Piston diameter
Fig. 30

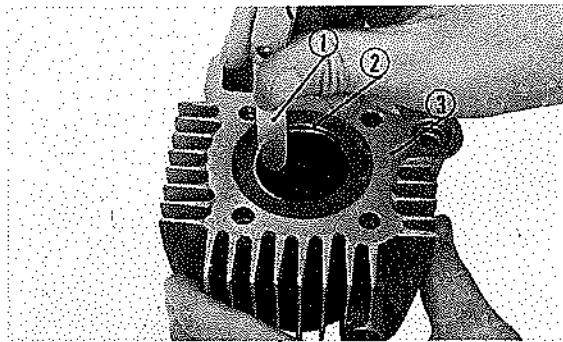

① Thickness gauge ② Piston ring ③ Cylinder
Fig. 31

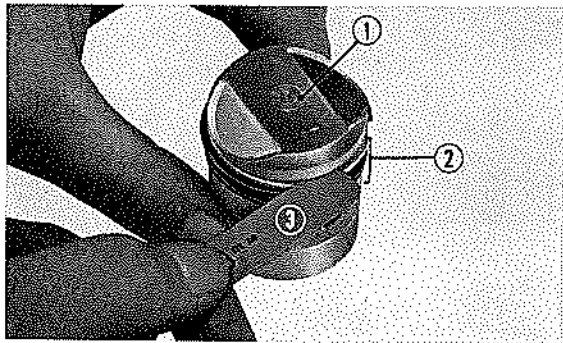

① Piston ② Piston rings ③ Thickness gauge
Fig. 32

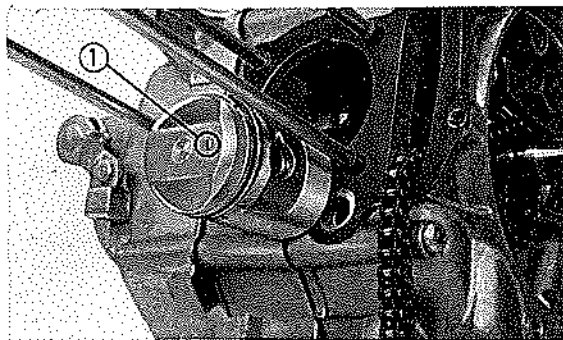

① Arrow mark
Fig. 33

C. Inspection

1. Measuring the piston

Measure the piston diameter at the piston skirt at right angle to the piston pin axis using a micrometer (Fig. 30).

Standard Value	Serviceable Limit
1.5346~1.5354 (38.98~39.00 mm)	Replace if under 1.73 (38.88 mm)

2. Measuring the piston ring end gap

Insert the piston ring into the cylinder and measure the ring end gap with a thickness gauge (Fig. 31).

Standard Value	Serviceable Limit
0.004~0.012 (0.1~0.3 mm)	Replace if over 0.02 (0.5 mm)

3. Measuring the piston ring side clearance

Measure the clearance between the piston ring and piston land with a thickness gauge (Fig. 32).

Item	Standard Value	Serviceable Limit
Top and second rings	0.0006~0.0018 (0.015~0.045 mm)	Replace if over 0.0039 (0.1 mm)
Oil ring	0.0004~0.0018 (0.010~0.045 mm)	Replace if over 0.0039 (0.1 mm)

4. Piston and piston ring are available in four standard oversizes of 0.01 (0.25 mm) up to 0.04 (1.0 mm).

D. Reassembly

Perform the reassembly in the reverse order of disassembly as described on page 9~10 and 13~14.

Note :

When assembling the piston to the connecting rod, make sure that the arrow marked on the piston head is pointing downward. (Fig. 33)

7. CLUTCH

A. Description

The clutch is a wet multiple disc, automatically engaging, centrifugal type. The gear change operation can be performed smoothly since the gear change mechanism is interconnected with the clutch pedal and when the clutch pedal is depressed, the ball retainer will be activated and causes the clutch to disengage.

As the engine speed increases the rollers are forced outward by the centrifugal force causing the clutch plate and friction disc to engage, permitting the power from the crankshaft to be transmitted to the transmission (Fig. 34).

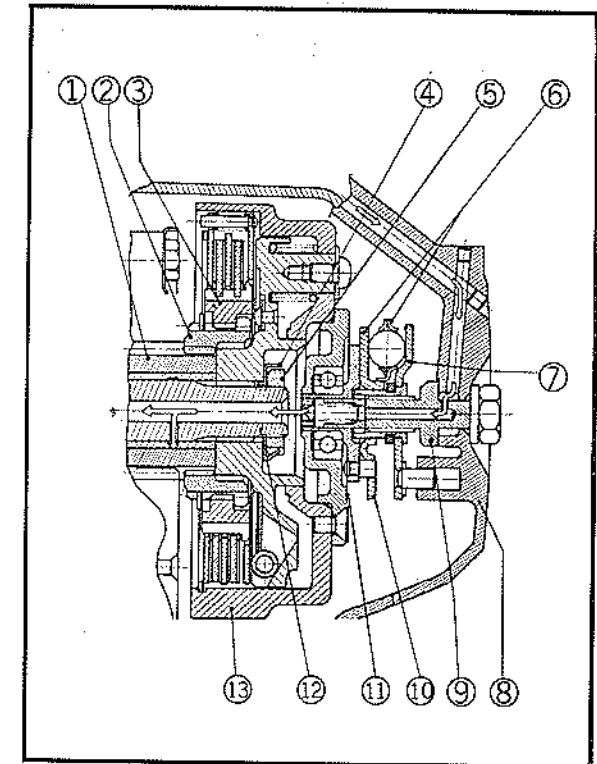

① Primary drive gear ② Drive outer
③ Clutch center ④ 14 mm lock washer
⑤ 14 mm lock nut ⑥ Ball retainer complete
⑦ Clutch lifter plate ⑧ Right crankcase cover
⑨ Clutch adjusting bolt ⑩ Clutch complete
⑪ Clutch outer cover ⑫ Crankshaft
⑬ Clutch outer
Fig. 34

B. Disassembly

1. Loosen the right crankcase cover retaining screws and remove the cover.
2. Remove the clutch outer cover.
3. Straighten the tab on the lock washer and by using the clutch outer holder (Tool No. 07024-03501) and lock nut wrench (Tool No. 07086-00102), loosen the lock nut and remove the clutch assembly (Fig. 35).

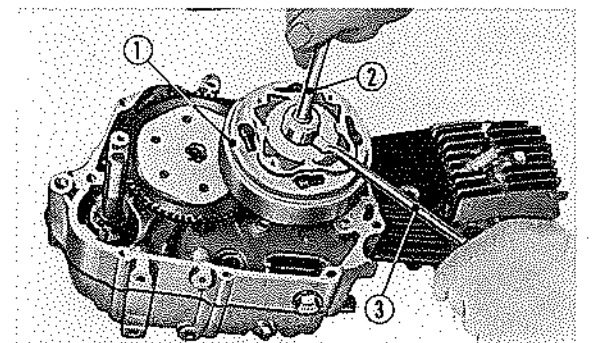

① Clutch outer ② Lock nut wrench
③ Clutch outer holder
Fig. 35

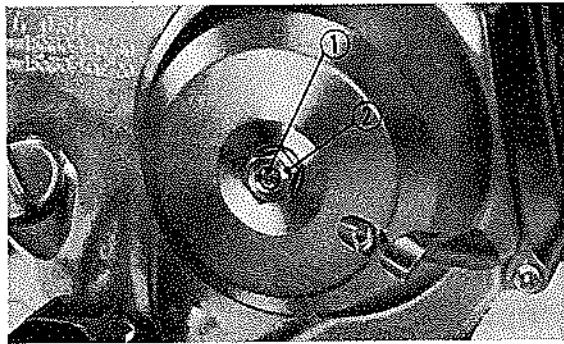

① Clutch adjuster ② Lock nut
Fig. 36

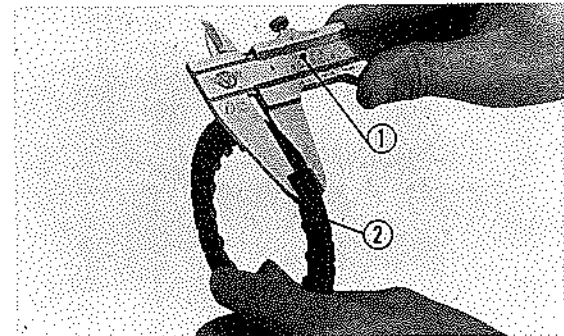

① Vernier caliper ② Friction disc
Fig. 37

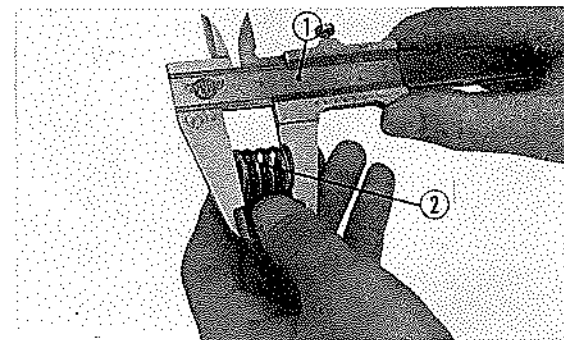

① Vernier caliper ② Clutch spring
Fig. 38

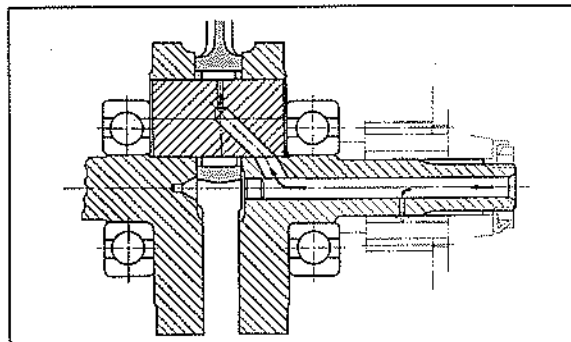

Fig. 39 Oil flow

C. Inspection

1. Clutch adjustment.

- a. Clutch must be adjusted with the engine shut off. Loosen the adjuster lock nut.
- b. Turn the adjuster clockwise about one turn; do not turn excessively.
- c. Next, slowly turn the adjuster counterclockwise and stop when the adjuster to turn heavy.
- d. From this point, back off the adjuster in the clockwise direction $\frac{1}{8}$ to $\frac{1}{4}$ turn, and tighten the lock nut (Fig. 36).

Check to make sure that the clutch operates properly after adjustment.

- The engine should start easily with the kick starter without the clutch slipping.
- When changing gear, the clutch slipping should be smooth and light, especially when shifting down in gear to the neutral position.

2. Measuring the friction disc
Measure the thickness of the friction disc using a vernier caliper (Fig. 37).

Standard Value	Serviceable Limit
0.138 (3.50 mm)	Replace if under 0.122 (3.10 mm)

3. Inspecting the clutch spring
Measure the free length of the spring using a vernier caliper (Fig. 38).

Standard Value	Serviceable Limit
0.772 (19.6 mm)	Replace if under 0.72 (18.2 mm)

D. Reassembly

Perform the reassembly in the reverse order of disassembly as described in page 16.

8. CRANKSHAFT

A. Description

The connecting rod is assembled on the crank pin. The bearing at the large end is lubricated by the pressurize oil which flows through the crankshaft (Fig. 39).

B. Disassembly

1. Remove the cylinder head and cylinder in accordance with the procedure described on page 9~10.
2. Remove the clutch assembly in accordance with the procedure described on page 16.
3. Remove the primary driven gear and the kick starter spring.
4. Remove the oil pump.
5. Remove the gear shift stopper and plate.
6. Loosen the left crankcase cover screws and then remove the cover, flywheel, stator and the cam chain.
7. Pull off the rubber plug and remove the gear shift drum stopper bolt.
8. Remove the final drive sprocket.
9. Remove the right crankcase.
10. Lift out the crankshaft assembly from the case.

C. Inspection

1. Measuring the crankshaft balance
Support the crankshaft on V-blocks at the bearings. Rotate the crankshaft and measure the amount of runout at both ends of the crankshaft using a dial gauge (Fig. 40).

Item	Standard Value	Serviceable Limit
Left end, at 1.2 (30 mm) from the weight	0.0006 (0.015 mm)	Repair if over 0.002 (0.05mm)
Right end, at 1.0 (25 mm) from the weight		

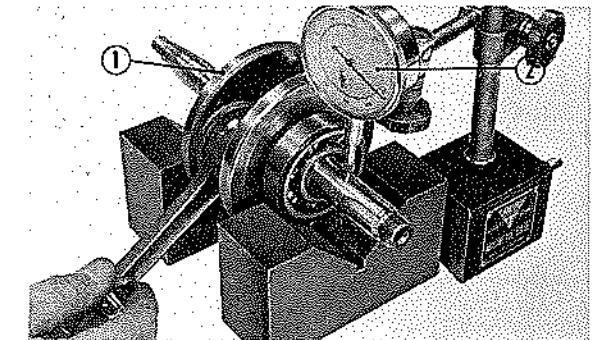

① Crankshaft ② Dial gauge
Fig. 40

2. Measuring the connecting rod side play.
Measure the amount of connecting rod side play using a thickness gauge (Fig. 41).

Standard Value	Serviceable Limit
0.004~0.014 (0.1~0.35 mm)	Replace if over 0.0315 (0.80 mm)

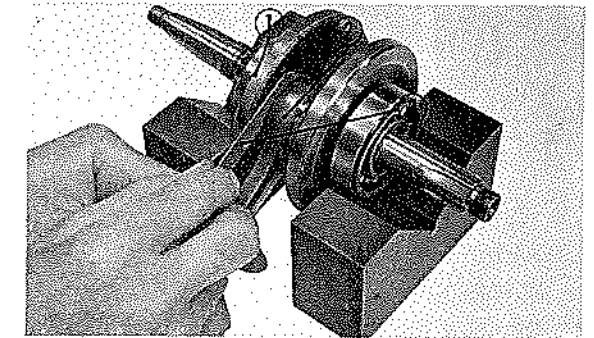

① Crankshaft ② Connecting rod ③ Thickness gauge
Fig. 41

3. Measuring the radial clearance of the connecting rod large end bearing.
Measure the amount of clearance at the connecting rod large end by using a dial gauge (Fig. 42).

Standard Value	Serviceable Limit
0.0005 max. (0.012 mm max.)	Replace if over 0.002 (0.05 mm)

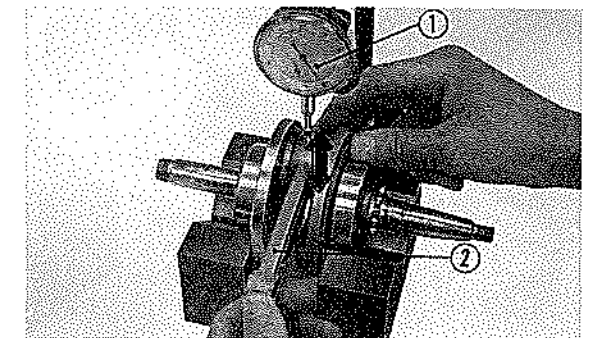

① Dial gauge ② Connecting rod
Fig. 42

D. Reassembly

Perform the reassembly in the reverse order of disassembly.

9. TRANSMISSION

This motorcycle use a constant mesh three speed transmission.

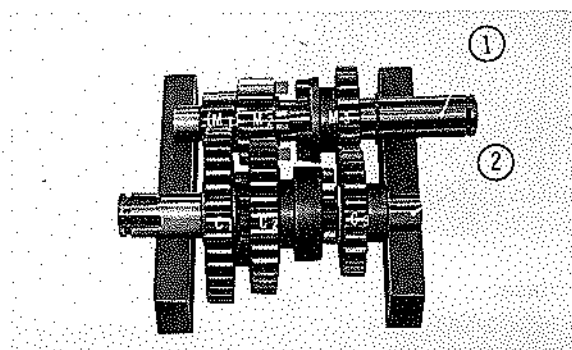

① Transmission mainshaft
② Transmission countershaft
Fig. 43-A Neutral position

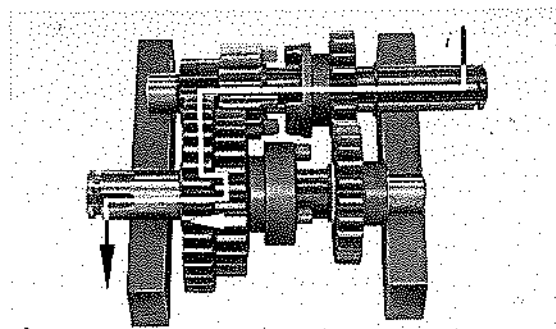

Fig. 43-B Low gear (C₂ shifted)

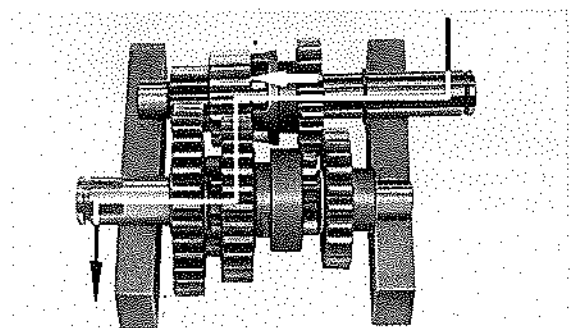

Fig. 43-C 2nd gear (M₂ shifted)

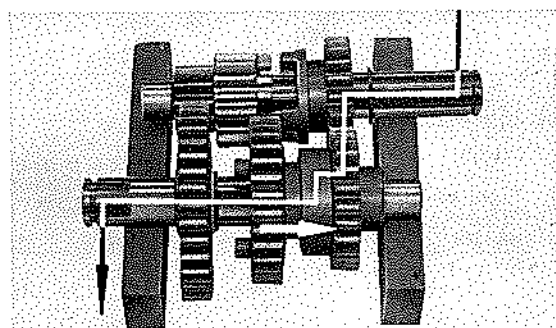
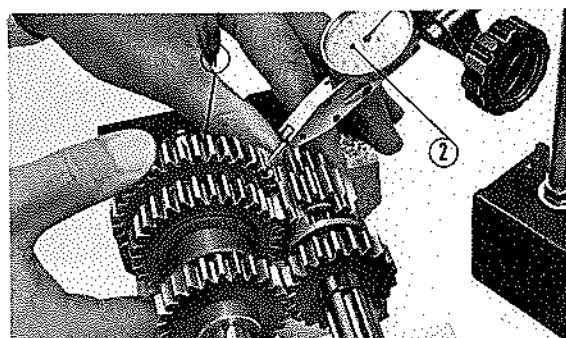

Fig. 43-D Top gear (C₂ shifted)

B. Disassembly

Perform the disassembly in accordance with the description in the section on crankshaft disassembly on page 18.

Remove the right crankcase and then remove the mainshaft, countershaft gear assembly and the gear shift fork assembly together as the unit.



① Gear ② Small dial gauge
Fig. 44

C. Inspection

- Measuring the gear backlash
Lock one gear of the gear set being measured and measure the amount of gear movement in the free gear using a dial gauge (Fig. 44).

Item	Standard Value	Serviceable Limit
Low gear	0.0033~0.0067 (0.085~0.169 mm)	Replace if over 0.010 (0.25 mm)
2nd gear	0.0035~0.0071 (0.089~0.179 mm)	Replace if over 0.010 (0.25 mm)
Top gear	0.0033~0.0067 (0.084~0.170 mm)	Replace if over 0.010 (0.25 mm)

2. Wear of the gears

When the gears has been used over a long period the gear teeth and the dog will wear and will also tend to make contact on the side, producing noise and causing the dog slip out. Under such condition, the gears should be replaced in sets for satisfactory performance.

3. Measuring clearance between the gear and shaft

Measure the diameter of the gear shaft bore with a cylinder gauge or and inside micrometer and measure the shaft diameter with a micrometer. From the two value compute the clearance.

(Reference)

Gears	Standard Value	Serviceable Limit
Mainshaft	0.0009~0.0024	Replace if over
2nd gear	(0.022~0.060 mm)	0.0039 (0.10 mm)
Countershaft	0.0012~0.0030	Replace if over
low and top gears	(0.032~0.077 mm)	0.0039 (0.10 mm)

Item	Standard Value
Gear ^s shaft bore	0.6699~0.6709 (17.016~17.043 mm)
Mainshaft diameter	0.6686~0.6690 (16.983~16.994 mm)
Countershaft diameter	0.6679~0.6686 (16.966~16.984 mm)

4. Checking the operation of the respective gears

Shift the gears into the neutral position and check to make sure that all of the gears rotate smoothly and or slide smoothly.

D. Reassembly

Perform the reassembly in the reverse order of disassembly, however, exercise care on the following points.

- 1 Assemble the respective gears, washers and circlips properly in the accordance with Fig. 45.
- 2 Replace all circlips with new items.

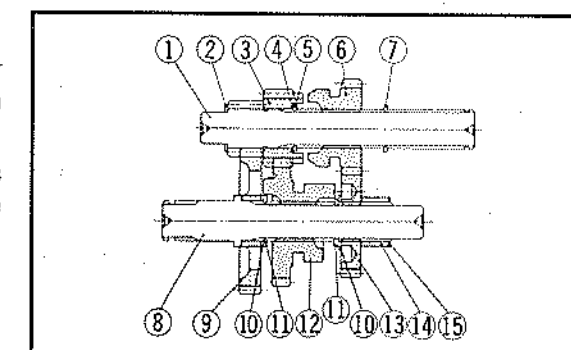

① Transmission mainshaft ② Thrust washer
③ Mainshaft second gear ④ 17 mm spline washer
⑤ 17 mm circlip ⑥ Mainshaft top gear
⑦ 17 mm circlip ⑧ Transmission countershaft
⑨ Countershaft low gear ⑩ 17 mm spline washer
⑪ 17 mm circlip ⑫ Countershaft second gear
⑬ Countershaft top gear ⑭ Gear collar
⑮ 13.5 mm thrust washer
Fig. 45

10. GEAR SHIFT MECHANISM

A. Description

The gear spindle arm which is connected to the gear shift spindle rotates the gear shift drum and this causes the gear shift fork to move left and right in the drum groove. The gear shift fork is controlled by the groove in the drum and this in turn causes the gears to slide and change gears.

B. Disassembly

- Refer to the section on disassembly of the crankshaft assembly on page 18.
By removing the right crankcase, the gear shift drum and the fork assembly can be removed together with the transmission gear as a complete unit.

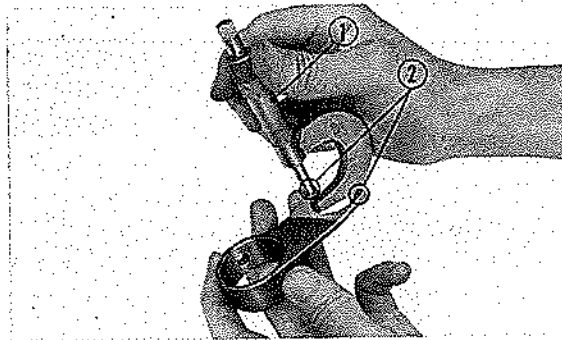

① Micrometer ② Gear shift fork ends
Fig. 46

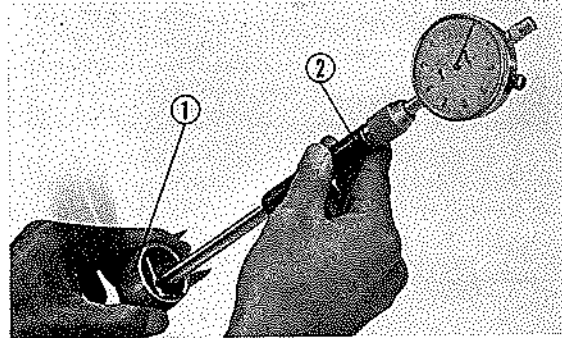

① Gear shift fork ② Cylinder gauge
Fig. 47

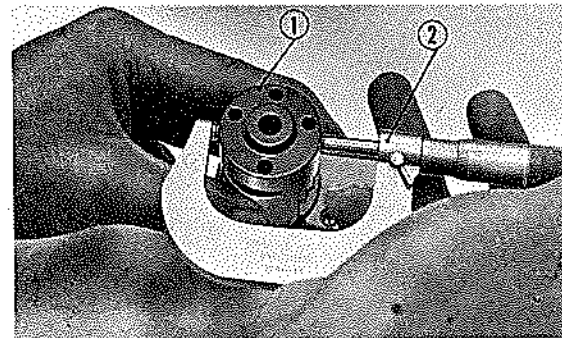

① Gear shift drum ② Micrometer
Fig. 48

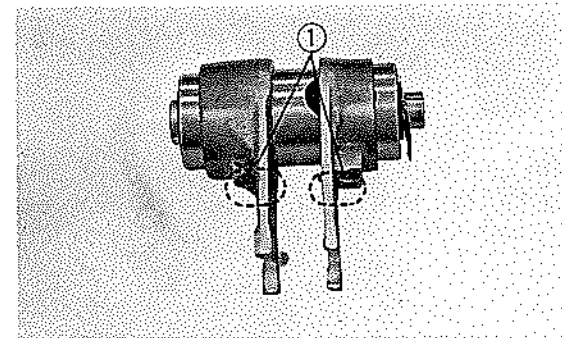

① Guide pin clip
Fig. 49

C. Inspection

1. Measuring thickness of the gear shift fork ends
The thickness of the shift fork end is measured with a micrometer (Fig. 46).

Standard Value	Serviceable Limit
0.191~0.195 (4.86~4.94 mm)	Replace if under 0.181 (4.6 mm)

2. Measuring the inside diameter of the gear shift fork
The inside diameter of the gear shift fork is measured with a cylinder gauge or an inside micrometer (Fig. 47).

Standard Value	Serviceable Limit
1.3385~1.3395 (34.0~34.025 mm)	Replace if over 1.346 (34.2 mm)

3. Measuring the outside diameter of the gear shift drum
The diameter is measured with a micrometer (Fig. 48).

Standard Value	Serviceable Limit
1.3366~1.3377 (33.95~33.98 mm)	Replace if under 1.335 (33.9 mm)

D. Reassembly

Perform the reassembly in the reverse order of disassembly, however, exercise care on the following points.

Make sure that the guide pin and guide pin clip are properly installed on the gear shift drum for both the right and left shift forks (Fig. 49).

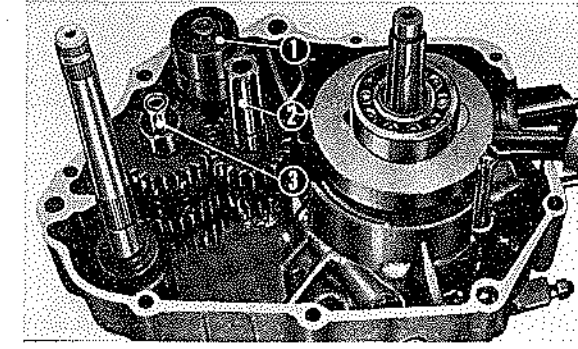

① Gear shift drum ② Mainshaft ③ Countershaft
Fig. 50

11. KICK STARTER

A. Description

When the kick starter is operated, the kick starter spindle will rotate counterclockwise. The kick starter pinion being engaged to the countershaft low gear transmits the rotary force to the crankshaft through main shaft. When the kick pedal is released the kick starter disengages from the low gear and there is no longer the transmission of force (Fig. 51).

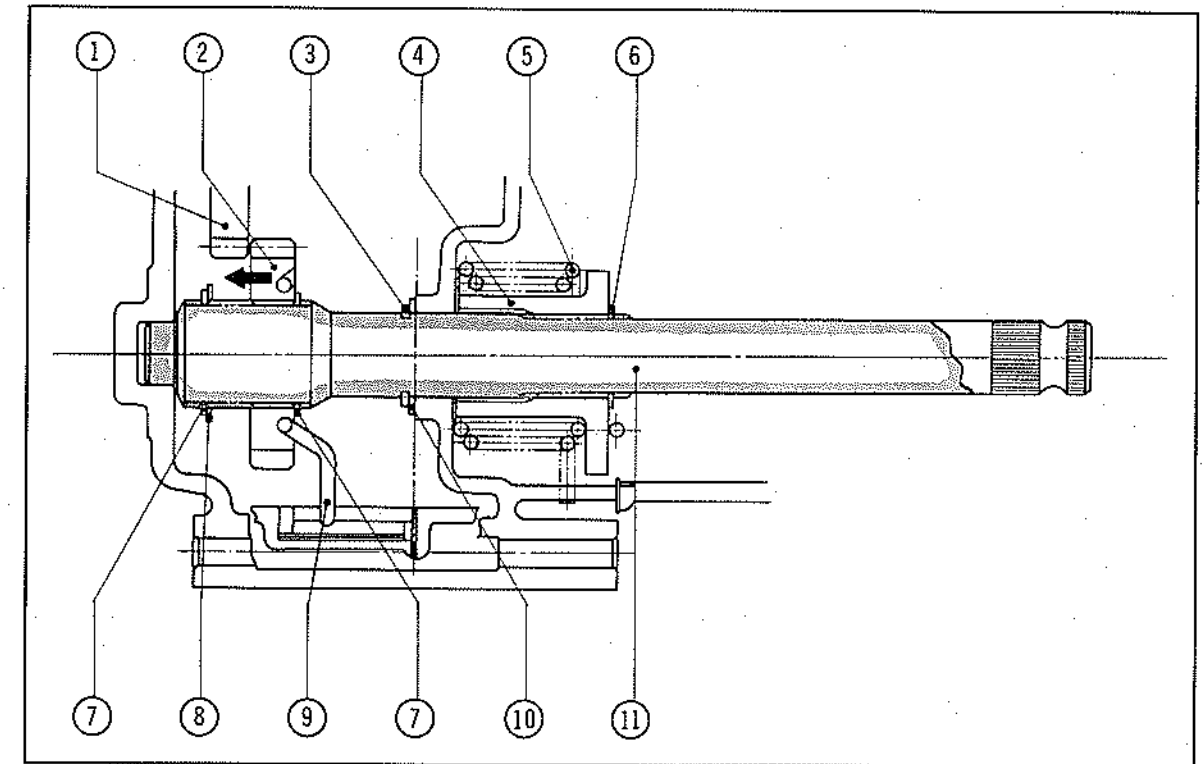

① Countershaft low gear ② Kick starter pinion ③ 17 mm circlip ④ Kick spring retainer
⑤ Kick starter spring ⑥ 16 mm circlip ⑦ 20 mm set ring ⑧ 20 mm washer ⑨ Kick starter ratchet spring
⑩ 17 mm thrust washer ⑪ Kick starter spindle
Fig. 51

B. Disassembly

1. Refer to the section on disassembly of the crankshaft on page 18.
By removing the right and left crankcases, the kick starter spindle assembly can be removed.

C. Inspection

- Check to make sure that the kick starter pinion is operating smoothly.

D. Reassembly

1. Perform the reassembly in the reverse order of the disassembly.

12. CARBURETOR**A. Description**

The carburetor mixes the fuel and air taken into the engine in a correct proportion to produce a mixture and which is further atomizes so that it is easily combustible. The construction of the carburetor is shown in Fig. 52.

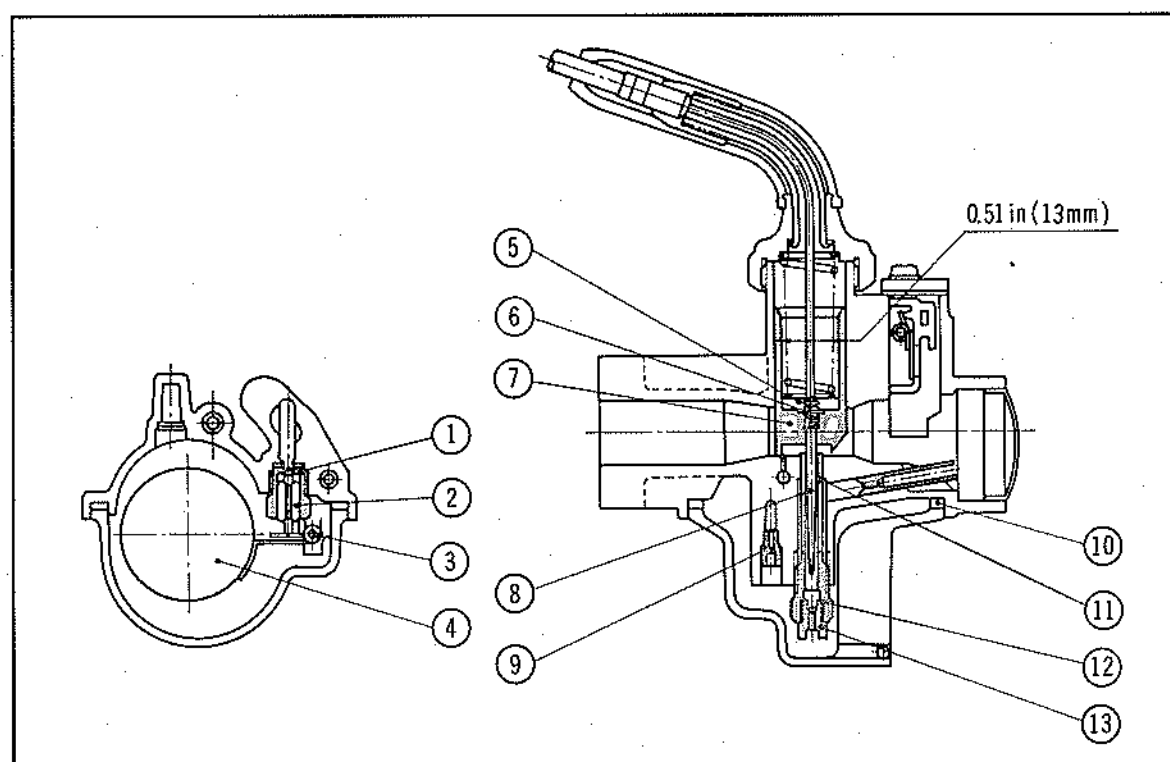

① Float valve seat ② Float valve ③ Float arm pin ④ Float ⑤ Needle clip plate ⑥ Needle clip
⑦ Throttle valve ⑧ Jet needle ⑨ Slow jet ⑩ Float chamber washer ⑪ Needle jet
⑫ Needle jet holder ⑬ Main jet

Fig. 52

Item		Specification
Setting mark		Z50M II
M.J. (Main Jet)		# 50
A.J. (Air Jet)		# 100
A.B. (Air Bleed)	AB 1	0.5×2
	AB 2	—
	AB 3	—
	AB 4	0.5×2
	AB 5	0.5×2
N.J. (Needle Jet)		2.1 mm (0.083 in.)×3R
J.N. (Jet Needle)		2°, 2 Steps, 2.05 mm (0.0907 in.)
C.A. (Cut away)		# 2 (Cut away), Width 1 mm (0.0394 in.) Depth 0.2 mm (0.0079 in.)
A.S. (Air Screw)		1 3/8 ± 1/8
P.J. (Pilot Jet)		# 38
V.S. (Valve Seat)		0.6 mm (0.024 in.)
B.P. (By-pass)		0.9 mm (0.035 in.) P=5.3 mm (0.209 in.)
Main Bore		9 mm (0.354 in.)
Fuel Level		18 mm (0.709 in.)

B. Removal

1. Turn the fuel cock to the OFF position and disconnect the fuel tube from the carburetor.
2. Remove the cap and disconnect throttle cable from the throttle valve.
3. Unscrew the two carburetor mounting bolts to remove the carburetor.
4. Loosen the air cleaner tube connecting clamp and separate the air cleaner assembly from the carburetor.
5. Remove air cleaner cover and lift out the air cleaner element.

C. Inspection

1. Washing the components
After the carburetor has been disassembled, wash the parts in solvent (or gasoline) and dry with compressed air.
2. Inspecting the float
Shake the float to see if there are any gasoline contained inside or for any deformation of the float. If the float contain the gasoline or is deformed, replace it with a new float.
3. Carburetor adjustment
 - a. Adjusting the idle
The idling is adjusted in the following manner with the throttle stop screw and the air screw.
 - (1) Sets the engine to the proper idling speed (1200 rpm) with the throttle stop screw.

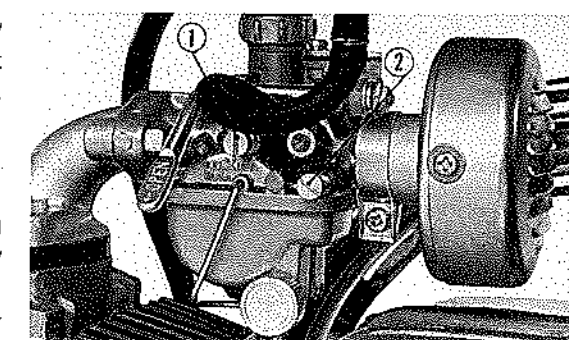

① Throttle stop screw ② Air screw
Fig. 53

- (2) Next turn the air screw slowly back and forth to obtain the point of the highest rpm.
- (3) If the engine rpm has increased as result of section (2) above, reset the engine speed back to the proper rpm with the throttle stop screw.
- (4) Once again manuplate the air screw to see if the rpm will be increased.
- (5) If the speed should increase again, perform section (3) (4) above again.

However, the adjustment of the air screw should be within $1\frac{3}{8} \pm \frac{1}{8}$ of a turn.

b. Adjusting the slow speed

The fuel mixture adjustment between idle to $\frac{1}{8}$ throttle opening is made by the air screw and the cut away on the throttle valve.

(1) Air screw

Turning in the clockwise direction will produce a rich mixture.

(2) Throttle valve cut away

In the vicinity $\frac{1}{8}$ throttle opening, there may be cases where the fuel mixture cannot be adjusted by the air screw only. In such case, if the fuel mixture is too rich, the throttle valve must be replaced with one having a cutaway of a large number size and then readjust the air screw.

c. Adjusting intermediate speed

At the throttle opening range between $\frac{1}{8}$ - $\frac{3}{4}$ the fuel mixture adjustment is made primary by the position of the jet needle steps and replacement of the cut away of the throttle valve. However, changing the cutaway of the throttle valve will also affect the throttle opening between the $\frac{1}{4}$ to $\frac{1}{8}$, therefore, the adjustment of the intermediate speed by replacing the throttle valve cut away only is very difficult. It is recommended that the adjustment for the intermediate speed be made by the jet needle, and stay within the range of acceptable acceleration performance since this would provide greater fuel economy.

d. Adjusting the high speed

While driving at high speed, if the speed increases when the choke is closed slightly, it is an indication that the carburetor is set too lean. Progressively replace the main jet with one of a large size and readjust the carburetor.

Note: Main jet sizes are numbered in the following manner:

Above # 100: 105, 110, 115
Below # 100: 98, 95, 92, 90

If the speed drops when the choke is closed slightly, it indicates that the main jet is either of the proper size or that it is too large, in which case, perform the following check to make the determination.

o Proper jet size

Progressively replace the main jet with one of a smaller size until there is a drop in speed and the speed increases when the choke is closed slightly, the installed jet is too small and should be replaced with one of a size larger, this is the proper jet size.

TROUBLE SHOOTING CHART

(CARBURETOR)

Troubles	Probable Cause	Remedy	Procedure
Engine will not start	Fuel cock in the closed position.	Position cock to the open position.	
	Insufficient fuel.	Pour fuel or position cock to RES position.	
	Excessive use of choke has resulted in carburetor flooding.	Clean spark plug.	Perform starting with the choke lever opened and the throttle at full open.
	Clogged or frozen fuel line.	Clean	<ul style="list-style-type: none"> • Clogged air vent icing condition, dirt clogged in valve. • Clean water which has accumulated in the float chamber (exercise care if water is frozen). • Condition outside of the carburetor will be clogged tank vent, strainer clogged with dirt or ice, clogging of the fuel lines.
	Flooding	Repair	Refer to section on flooding.
Poor idling performance	Readjust air screw	Adjust	Turn the air screw in all the way lightly and then back off to the standard setting of 1-3/8 open. Start the engine and turn the air screw back and forth approximately 1/8 turn to locate the point where the engine speed is the highest. Finally, set the idle speed with the throttle stop screw.
	Throttle stop screw	Adjust	Turning screw in will result in increased engine speed. Turning screw out will result in decreased engine speed. When turning screw out will not effect decrease in engine speed, adjust with the cable adjuster.
	Clogged slow jet or loosened jet	Clean or retighten the jet.	When slow jet is clogged, disassemble the carburetor, remove the screw and clean out with compressed air.
	Carburetor flooding	Repair	Refer to section on flooding.
Poor intermediate speed performance	Clogged slow jet or loosened jet.	Clean or retighten the jet.	Refer to section above.
Not able to operate at cruising speed	Clogged air vent pipe	Clean	Remove the air vent pipe and clean.
	Float level	Adjust float level	If needle valve is worn, replace with a new part.
	Improper setting of the jet needle	Adjust if necessary	Normally set the needle to the third step, however, there may be a difference of one step for winter and summer.

Troubles	Probable Cause	Remedy	Procedure
Poor high speed performance	Choke left in closed position	Open choke full	Set the choke lever to open.
	Fuel lever cock	Set to open or RES	Position the lever to one of the position.
	Clogged air vent	Clean	Remove and clean.
	Clogged main jet	Clean	Remove the main jet and clean out with compressed air before assembly.
	Dirty air cleaner	Clean or replace	
Overflow	Clogged float valve with dust.	Clean	Remove the float chamber cover. If there are accumulated dust, remove dust by blowing air or remove the valve seat and clean it.
	Damaged or worn valve and valve seat.	Replace as assembly.	Replace as valve assembly.
	Punctured float	Replace	Remove the float and shake to check if fuel is inside, replace.
	Clogged air vent	Clean	

(ENGINE)

Troubles	Probable Cause	Remedy	Procedure
Poor speed and powerless	Clutch slippage	Check and adjust	If the clutch friction disk is worn beyond serviceable limit, replace the parts with new. Also check its corresponding parts. See page 18.
	Air cleaner and tube	Check and clean	When the air cleaner element and air inlet tube are clogged, clean the element by air and remove the dust inside inlet tube.
	Ignition timing, tappet clearance and engine's knocking	Adjust and correct	Align the "F" mark on the flywheel to the index mark on the case. The contact breaker point should just begin to open this time. Correct the proper tappet clearance by using a thickness gauge.
	Compression pressure	Inspect, retighten and replace	Measure compression pressure by gauge. If gauge show less than 8.0 kg/cm ² . Replace the piston ring and others. Retighten the cylinder and cylinder head bolts.
	Spark plug	Clean or replace	Clean spark plug electrode using a stiff wire and adjust the electrode gap (0.024-0.028 in or 0.6-0.7 mm), or replace the proper heat range plug.

Troubles	Probable Cause	Remedy	Procedure
	Lubrication	Pour or change oil	Shortage of oil amount or inferior oil cause engine seazing and stick. Supply proper grade oil or change if necessary.
	Fuel	Check	Premium quality gasoline is being used.
High oil consumption	① Wear of engine's part	Replace	Worn piston, piston ring and cylinder should be replaced.
	② Clearance between valve and valve guide	Replace	Replace both valve and valve guide in case there are large clearance between them.
	③ Piston ring installation	Disassembling and inspect	Each piston ring must be installed properly on the piston and piston ring gaps must be staggered at 120° apart.
	④ Amount of oil	Check	When the oil was overfilled, drain the oil to bring to the proper oil level.
	⑤ Leakage	Check	Replace the gasket or oil seal and retighten the screws.

(CLUTCH MULFUNCTION)

Troubles	Probable Cause	Remedy	Procedure
Clutch slippage	Wear clutch plate and clutch friction disk and spring damage	Check and repair	Spring compressive force and free length are beyond the serviceable limit, they should be replaced. Replace the parts in case the clutch disks and plates are distorted or excessively worn.
Clutch stick	Oil and defective installation	Inspect and adjust	Readjust the clutch or replace the clutch disks and plates if necessary.
Chattering noise	Clutch spring	Check and adjust	Adjust the same height of clutch spring and replace if the springs are distorted.
Gear shift operation			
Not able to shift the gear	Gear, shift fork, shift arm, spring	Inspect and replace	① Broken, wear and damage of these parts should be replaced. ② Repair the gear shaft arm or drum if they do not operate smoothly.
Gear change pedal does not return to the normal position	Gear shift return spring and gear shift arm spring	Inspect	① Repair or replace if they are defectively.
Transmission gear jumping	Gear shift fork gear shift drum stopper spring	Repair	① If the gear shift fork finger is deformed or excessively worn, it should be replaced. ② Replace if the spring compressive force is inadequate.

Troubles	Probable Cause	Remedy	Procedure
Noise			
Tappet noise	• Tappet clearance	Adjust	Adjust the proper clearance if it is too large.
	• Wear of rocker arm and shaft	Replace	Replace the rocker arm and shaft if excessively worn.
Piston slap	• Large clearance between piston and cylinder	Replace	Piston or cylinder should be replaced, use its oversize of piston and piston ring.
	• Large clearance of bearing ends of connecting rod	Repair	Replace the worm parts when the connecting rod to piston pin or to crank pin clearance are excessively large.
Cam chain noise	• Cam chain tensioner, chain and wear of sprocket teeth	Adjust or replace	<ul style="list-style-type: none"> • Perform the adjustment or replacement if the cam chain tensioner is inoperative. • The stretched chain should be replaced. • Excessive worm teeth of sprocket (cam side, timing side) should be replaced.
Clutch chattering noise	Clutch outer and friction disk	Replace	• Replace the worn parts if there are excessive looseness between them.
Crankshaft noise	Bent center of crankshaft and crank pin, worn bearing	Align and replace	Align the crankshaft if there are excessive deflection at the center of crank shaft. Bent crank pin and worn bearing should also be replaced.
Primarily drive gear's noise	Drive or driven gear	Inspect and replace	Carefully check to the teeth face of drive or driven gear on which there are excessive wear, replace them.

FRAME

1. FRONT SUSPENSION

When assembling the front cushion, particular attention should be given to the following items.

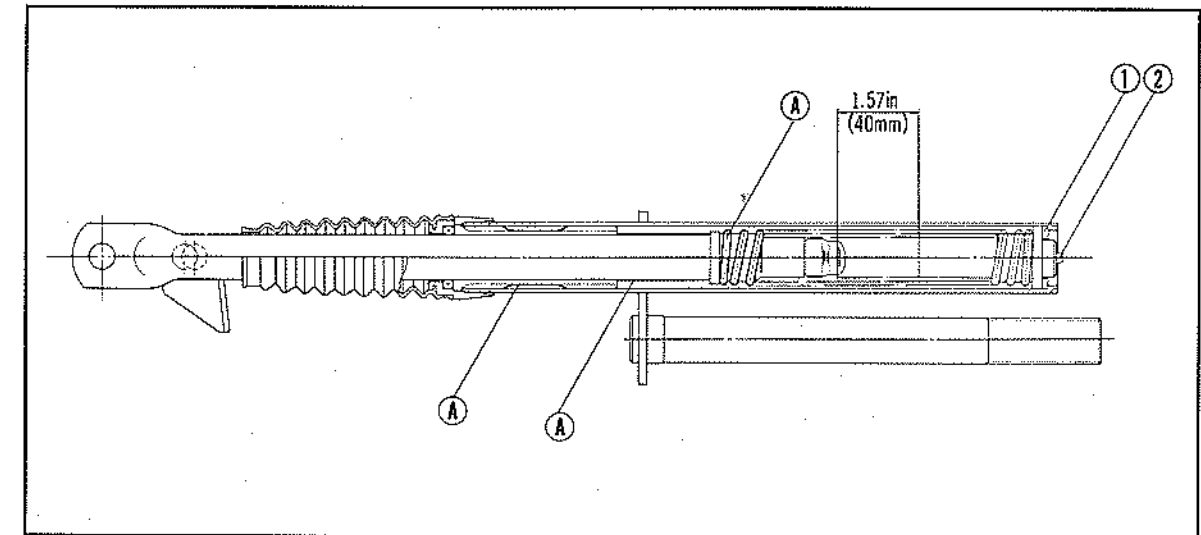

① Spring seat washer ② Dowel pin
Fig. 54

1. Apply ample amount of good quality grease to the area **A** indicated by heavy lines in Fig. 54 when installing the front fork cushion assembly to the front fork.
2. Do not forget to install the seat washer **①**.
3. Positively insert the alignment dowel pin **②** of the front fork cushion into the steering handle holder before tightening the bolts.

WIRING DIAGRAM

U.S.A. TYPE (From F. No. 100001)

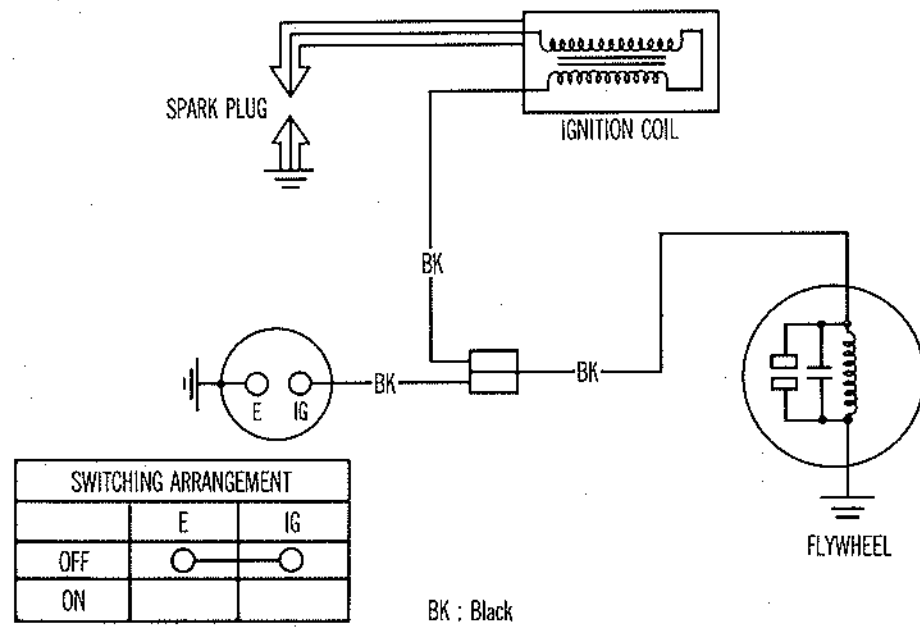

U.S.A. TYPE (From F. No. 120001)

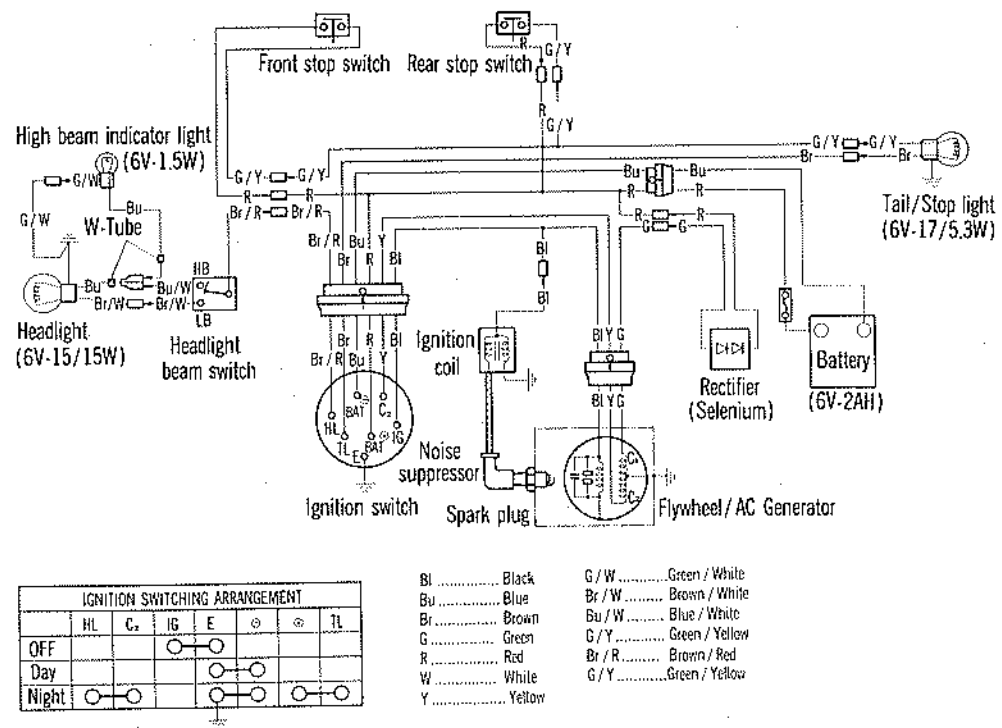

GENERAL EXPORT TYPE

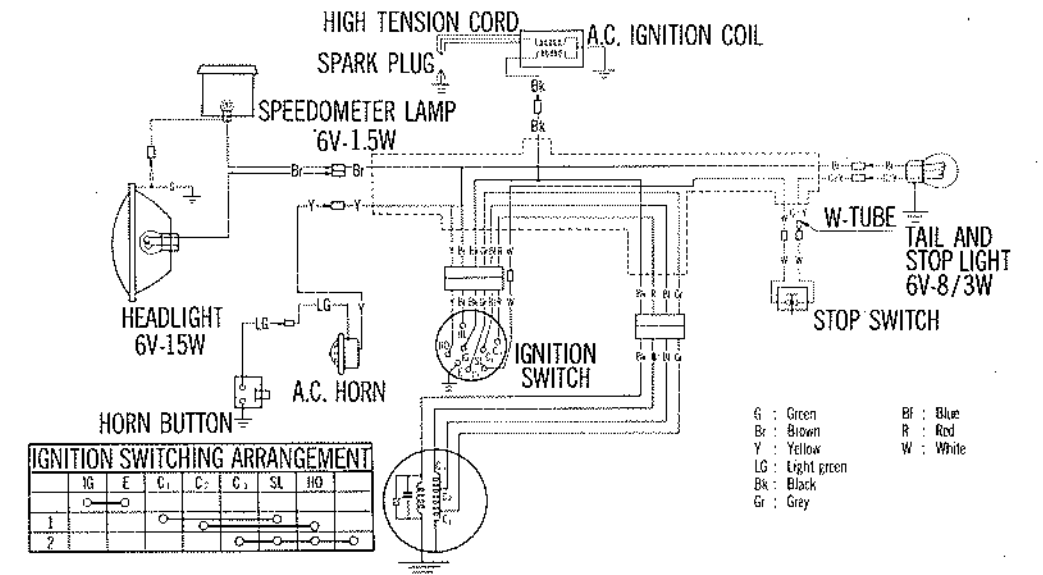

Honda 50 Model Z50A
SHOP MANUAL

Published by
HONDA MOTOR CO., LTD.
Foreign Service Department
SERVICE DIVISION
4429-1 Niikura Yamato-Machi Saitama-Ken, Japan

Printed by YAMAGATA PRINTING CO., LTD.
6-34, 2-chome, Takashima, Nishi-ku,
Yokohama, Japan
March, 1969

Copyright reserved